



Voice Mail System

Installation
And
Programming
Manual

Voice Mail System

Installation and Programming Manual

1. INTRODUCTION	1-1
1.1 FEATURES AND SERVICES	1-2
1.1.1 System Features.....	1-2
1.1.2 Automated Attendant Features.....	1-3
1.1.3 Voice Mail Features	1-6
1.2 ABOUT THIS MANUAL	1-8
2. DESCRIPTION AND INSTALLATION.....	2-1
2.1 THE BASIC SYSTEM.....	2-2
2.2 PHYSICAL DESCRIPTION.....	2-2
2.2.1 Side Panel.....	2-3
2.2.2 Front Panel.....	2-3
2.3 INSTALLATION	2-4
2.3.1 Unpacking	2-4
2.3.2 Installing the Unit.....	2-5
2.3.3 Expanding the System to Four Lines.....	2-7
3. DTMF PROGRAMMING.....	3-1
3.1 ENTERING AND EXITING THE PROGRAMMING MODE.....	3-1
3.2 FIRST TIME PROGRAMMING CHECKLIST	3-2
3.3 DEFINING PBX PARAMETERS	3-3
3.4 SETTING THE TIME AND DATE	3-8
3.5 PROGRAMMING THE OPERATIONAL MODE	3-8
3.6 PROGRAMMING THE UNIT	3-10
3.6.1 Creating Mailboxes.....	3-10
3.6.2 Creating Mailbox Groups	3-12
3.6.3 Notification.....	3-13
3.7 PROGRAMMING THE AUTOMATED ATTENDANT SCRIPT MENU.....	3-17
3.7.1 Recording Script Messages	3-17
3.7.2 Programming Script Messages	3-18
3.7.3 Directory Listing Programming.....	3-25

Table of Contents

3.7.4	<i>Reset Script Message Programming to Default</i>	3-26
3.7.5	<i>Supervised, Semi-Supervised and Non-Supervised Transfers</i>	3-26
3.8	ADDITIONAL FEATURES	3-29
3.8.1	<i>Changing Passwords</i>	3-29
3.8.2	<i>Activate Force Reorganize</i>	3-30
3.8.3	<i>Changing to/from Day Light Saving Time</i>	3-31
3.8.4	<i>Changing the Operational Mode</i>	3-31
3.8.5	<i>Playing a System Message</i>	3-32
3.8.6	<i>Playing All System Messages</i>	3-32
3.8.7	<i>System Message Setting</i>	3-32
3.8.8	<i>Listening to the Software Version Number</i>	3-33
3.8.9	<i>Resetting the System</i>	3-33
3.8.10	<i>Adjusting Recording Length</i>	3-33
4.	PROGRAMMING BY COMPUTER	4-1
4.1	CONNECTING THE UNIT TO THE COMPUTER	4-1
4.2	SYSTEM REQUIREMENTS	4-2
4.3	INSTALLING THE VUP	4-2
4.4	STARTING VUP	4-3
5.	USER OPERATION INSTRUCTIONS	5-1
5.1	INTRODUCTION.....	5-1
5.2	USER'S MAIN MENU	5-1
5.3	RETRIEVE MESSAGE MENU.....	5-1
5.4	MAILBOX PARAMETERS	5-2
5.4.1	<i>Record Greeting</i>	5-3
5.4.2	<i>Record Name</i>	5-3
5.4.3	<i>Directory Listing</i>	5-4
5.4.4	<i>Change Password</i>	5-4
5.4.5	<i>Do Not Disturb (DND)</i>	5-5
5.4.6	<i>External Notification</i>	5-5

5.4.7	<i>Pager Notification</i>	5-6
5.4.8	<i>Return to Previous Menu</i>	5-6
5.5	SEND MESSAGE.....	5-7
5.6	RETURN TO AUTO ATTENDANT.....	5-7
5.7	QUICK REFERENCE GUIDE	5-8
6.	PROGRAMMING THE IN-BAND DTMF PROTOCOL	6-1
6.1	PROGRAMMING THE UNIT BY TELEPHONE	6-1
6.1.1	<i>Defining an In-Band DTMF Code for an Event</i>	6-1
6.1.2	<i>Selecting an Operation Type</i>	6-3
6.1.3	<i>Selecting a destination</i>	6-4
6.1.4	<i>Defining the Time to Wait for the First DTMF Character</i>	6-4
6.1.5	<i>Defining the Time to Wait Between DTMF Characters</i>	6-4
6.1.6	<i>MATRA Support</i>	6-5
6.2	SAMPLE PROGRAMMING	6-5
6.2.1	<i>Working with the SIEMENS Hicom 150E Office PBX</i>	6-5
7.	TROUBLESHOOTING.....	7-1
	APPENDIX A PROGRAMMING COMMANDS	A-1
	APPENDIX B PROGRAMMING FORMS.....	B-1
	APPENDIX C SYSTEM MESSAGES	C-1
	APPENDIX D SPECIFICATIONS	D-1

1. INTRODUCTION

This unit is a small stand alone multilingual Voice Mail/Automated Attendant system for organizations that have between eight and eighty employees. This unit incorporates state of the art technology, including DSP, flash memory and SMT production.

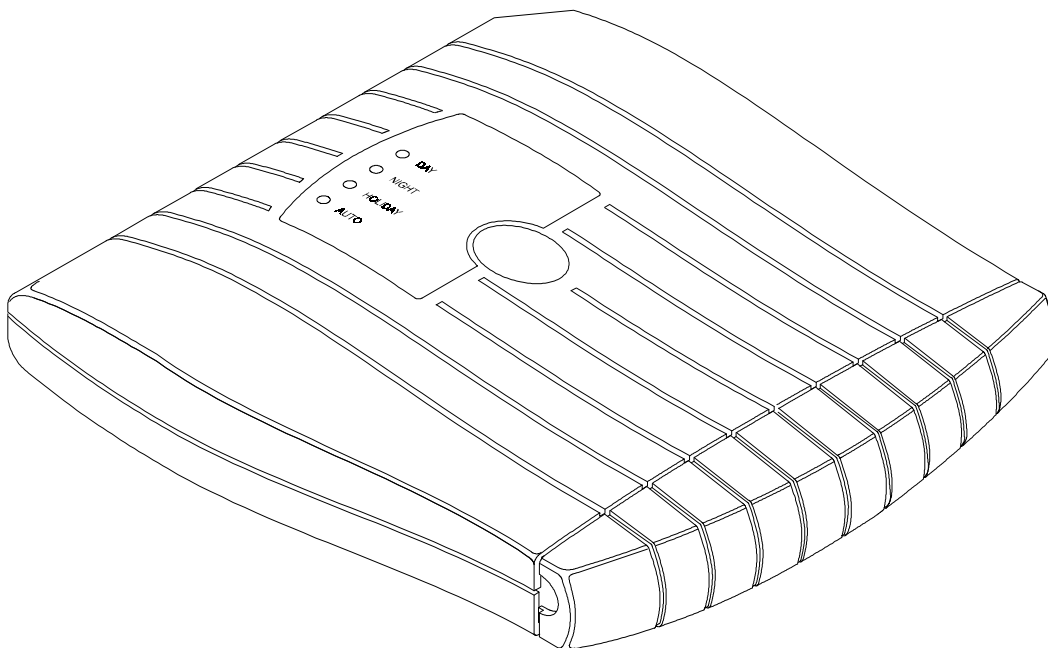

Figure 1-1 General View

The unit is available in two or four ports and with up to 128 mailboxes. It provides up to 10 hours of recording time.

The unit can be integrated with most types of PBX's through the analog ports or through the RS-232 serial port.

The system administrator can be programmed by the computer using the Voice Mail Utility Program (VUP) or by touch-tone telephone.

Installing the unit is quick and easy. Just mount it on a wall next to the PBX and connect it to the SLT interfaces and to the main power supply with an external power adapter.

The unit is ready for use immediately after the system administrator completes a short procedure that includes setting up integration parameters, mailboxes, notification type, system schedules and opening greetings. Mailbox owners can then set up their own personal mailbox parameters.

1.1 Features and Services

The unit is a powerful voice mail system at an affordable price. It contains most of the useful features and services provided by PC-based systems but at a lower cost. The unit's features can be divided into three groups:

- System Administration
- Automated Attendant
- Voice Mail

1.1.1 System Features

- **Configuration**

The unit is available with two ports and 10 hours of recording time. The system administrator can upgrade the unit by adding a two port expansion card to the motherboard to provide four ports

- **Programming**

The system administrator can program the unit by:

- Touch-tone telephone using DTMF tones
- Computer using the Voice Mail Utility Program (VUP). The installer should save the files containing the parameters set in each installation.

- **Integration with your PBX**

The system administrator can integrate the unit with the PBX through:

- In-Band DTMF Protocol integration using DTMF strings. This type of integration is achieved by setting up the communication parameters on the PBX and the units, including answering a call, transfer, recall from busy, recall from no answer, the notification parameters and more.
- Out-band integration through a serial port (RS-232) applying the PBX parameters to the unit. This type of integration must be developed separately for each type of PBX.

- **Loop Current Disconnection**

Some PBXs have the capability, which enables them to notify the unit through the line interface when a call is terminated. When this situation is detected by the Voice mail, the line is disconnected and the unit is then ready to receive another call.

- **Message Notification**

The unit automatically notifies the mailbox owner of new messages in different ways according to the system configuration. Notification may be local (to a PBX extension) or remote (to a telephone at a remote location, a cellular telephone or a pager).

- **Security Passwords**

The unit supports three types of passwords, each with four digits:

- *System Administrator*. Gives access to all data stored in the unit.
- *Operator*. Gives access to the operating modes of the system. The available operating modes are: Day, Night, Holiday and Break.
- *Mailbox*. Gives access to individual mailboxes. Mailbox owners can change the password at any time.

- **Line Monitor**

The unit sends all incoming DTMF codes to the VUP from all the ports, simultaneously through the RS-232 cable. The line monitor is a powerful tool to simplify the integration and installation of the unit with the PBX.

1.1.2 Automated Attendant Features

The unit's automated attendant answers incoming calls and through a series of recorded menus and telephone directories, helps the callers reach the desired extensions.

- **Opening Greeting**

The unit plays a pre-recorded greeting to callers. The opening greeting usually includes the organization's name, how to reach an extension, department or operator, how to switch languages, how to leave a message and to access a directory.

During the greeting, callers can access a department by dialing a single digit, dialing the extension number or holding for assistance.

- **Operating Modes**

Depending on the time and the system schedule, the unit answers external calls with one of four opening greetings:

- **Day Mode**

During normal business hours, the unit answers calls with a pre-recorded daytime greeting. The daytime greeting enables the caller to reach a requested extension, mailbox, department, and directory or to switch languages.

- **Night Mode**

During non-working hours, the unit answers calls with a pre-recorded nighttime greeting that enables the caller to leave a message in a requested mailbox.

- **Holiday Mode**

During holidays, the unit answers calls with a special greeting that enables the caller to leave a message in a specific mailbox or in the operator's mailbox.

- **Break Mode**

The system administrator can program part of the day mode as break time. During break time, the unit answers calls with a special greeting that enables the caller to leave a message in a specific mailbox or in the operator's mailbox.

- **System Schedules (Auto-Mode)**

If your organization has operating hours that vary from day to day, the system administrator can define the daily operating schedules on a weekly basis, including daytime, nighttime and break time hours. When the Auto mode is activated, the unit automatically switches between the day, night and break modes according to the pre-defined schedule.

The operator can override the pre-defined system schedule and switch manually to day, night, break, or holiday mode using a password.

- **Holiday Schedules**

The unit switches automatically to Holiday mode on dates programmed as holidays. During holidays the unit answers calls with the special holiday greeting.

- **Fax Detection**

If the unit detects a fax tone (CNG) during the opening greeting, it automatically transfers the call to the pre-defined fax extension.

- **Directory Listing (Dial By Name)**

The unit can provide a list of mailbox owner names. The directory listing enables calls to be transferred to all extensions configured within the list. A caller can access the directory listing by following instructions during the opening greeting.

In order to enable a directory listing call transfer, the mailbox owner must record his name and a three-letter code. A caller can reach the proper extension after dialing the respective code and verifying a correct extension according to the mailbox owner's name.

The system administrator enables two methods of directory listing: according to the mailbox owners first or last name.

- **Call Transfer**

The system administrator can program the unit to detect the Call Progress tone and DTMF signals sent by the PBX and transfer the calls to extensions in one of the following modes:

- **Non-Supervised.** The unit transfers the call immediately without verifying the status of an extension.
- **Supervised.** The unit checks for a busy or answer signal before transferring the call to an extension.
- **Semi-Supervised.** The unit only checks for a busy signal before transferring the call to an extension.

- **Multilingual Option**

The unit can operate in three languages simultaneously. The system administrator can configure each mailbox to operate in one of the three selected languages. The caller can select the language in which the system messages (prompts) are played.

- **Answering on the First Ring**

To avoid delays, the system administrator can set up the unit on each individual port to answer incoming calls on the first ring.

- **Script Menus**

The unit supports up to 39 script menus. A script menu is a recorded announcement that can accept a digit entry (0-9) during playback. Based on the digit entered, the unit can take one of the following actions:

- Transfer the call to another script menu
- Transfer the call to another script menu and change the language
- Transfer the call to an extension or hunt group
- Transfer the call to a mailbox or a mailbox group
- Dial a string of DTMF (10 different strings and up to 20 digits for each string including special characters)
- Retrieve messages from a mailbox
- Disconnect the line
- Leave a message
- Play the directory listing
- Record a call

1.1.3 Voice Mail Features

The unit enables a caller to leave a message, recorded in his own voice, in any mailbox. The mailbox owner can access his/her mailbox at any time from any touch-tone telephone and listen to his/her messages. Mailbox owners can also modify their own mailbox parameters.

- **Real/Virtual Mailboxes**

The unit supports up to 128 real and virtual mailboxes. A real mailbox has a telephone extension, whereas a virtual mailbox does not.

- **Personalized Mailboxes**

Mailbox owners can personalize their mailboxes by recording a personal greeting, assigning a personal password to the mailbox and setting optional parameters.

- **Personal Greeting**

Mailbox owners can record or change personal greetings at any time from any touch-tone telephone. Callers first hear the personal greeting of the extension called and then they can leave a message.

- **Day and Time Stamp**

The system administrator can program the unit to indicate the start of each message and the day and time it was recorded.

- **Message Deletion**

Mailbox owners can manually delete messages or the system administrator can program the unit to automatically delete all messages after a specified number of days.

- **Message Forwarding**

Mailbox owners can forward copies of messages to other mailboxes or mailbox groups. Mailbox owners can also record an introduction to the forwarded message.

- **Message Reply**

Mailbox owners can reply, directly, to a message and record a message in the sender's mailbox.

- **Mailbox Groups**

A caller can send a message to all the members of a mailbox group at one time.

All defined mailboxes belong to the "All Group" mailbox group. In addition, the system administrator can create up to four mailbox groups, each containing up to twenty mailboxes. Mailboxes can belong to more than one group and can be added to or deleted from a mailbox group by the system administrator. Each mailbox group can be assigned with a mailbox group greeting.

- **Do Not Disturb Mode**

Mailbox owners can set their mailboxes in the Regular Mode or Do Not Disturb Mode. When a caller dials a Do Not Disturb extension using the Automated Attendant menus, the unit plays a special "Do Not Disturb" menu and does not transfer the call to the extension.

- **Individual Language Selection**

The mailbox owner or caller can select one of the languages supported by the unit. When the mailbox owner or caller enters the mailbox, the unit automatically switches to the selected language.

- **Adjustable Recording Length**

The system administrator can select the length of all recorded messages in the unit. The selected length will control the following types of messages: scripts,

greetings, names and incoming messages. Changing this parameter will affect the operation unit.

- **Automatic Gain Control (AGC)**

When this feature is enabled, the unit automatically adjusts the line volume so incoming messages will be recorded at the same level.

1.2 About this Manual

This manual presents information needed to install, program and maintain the unit. It is divided into the following sections:

1. **INTRODUCTION**

Introduces the unit and lists its features.

2. **DESCRIPTION AND INSTALLATION**

Provides a functional description of the unit and installation instructions.

3. **DTMF PROGRAMMING**

Describes how to program the unit from any DTMF telephone.

4. **PROGRAMMING BY COMPUTER**

Describes the installation and basic operational concepts of the Voice Mail Utility Program (VUP).

5. **USER OPERATING INSTRUCTIONS**

Explains how to program and use a mailbox.

6. **PROGRAMMING THE IN-BAND PROTOCOL**

Describes how to program the unit to detect the In-Band DTMF protocol sent by the PBX.

7. **TROUBLESHOOTING**

Presents answers to commonly asked questions on operating the unit.

APPENDIX A

Summarizes the programming commands.

APPENDIX B

Contains the DTMF programming forms.

APPENDIX C

Lists the system messages.

APPENDIX D

Lists the system specifications.

2. DESCRIPTION AND INSTALLATION

The unit is a digital system consisting of a:

- Sophisticated DSP voice-processing device
- Flash memory for storing voice recording and parameter data
- Central Processing Unit
- Two or four ports
- Real-time clock

The unit provides two major services:

- **Automated Attendant**

Uses menus and sub-menus to transfer calls to specific departments, extensions or mailboxes.

- **Voice Mail**

Receives and delivers messages. Each mailbox has its own number and mailbox owners have passwords enabling them access to their mailboxes.

Messages can be saved, deleted or transferred to other mailboxes. Mailbox owners can also send identical messages to groups of mailboxes or to all the mailboxes in the system.

By configuring the following, the unit's Automated Attendant and Voice Mail System can be customized to suit the needs of the company:

- PBX parameters
- Automated Attendant script menus and customized "Busy", "No Answer" and "Do Not Disturb" menus in up to three different languages simultaneously.
- Voice Mail features include: mailboxes, mailbox groups and various types of message notifications for each mailbox

2.1 The Basic System

The unit comes with two lines and 10 hours recording time. You can upgrade the unit by adding a two line expansion card to the motherboard to provide four lines

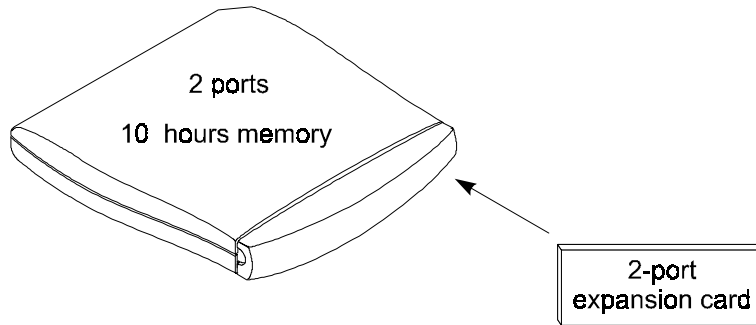

Figure 2-1 Options for Upgrading the Basic System

2.2 Physical Description

The functional components of the unit are located under the side panel cover. The LEDs are on the left side of the front panel. The bottom panel has two indented holes for wall mounting.

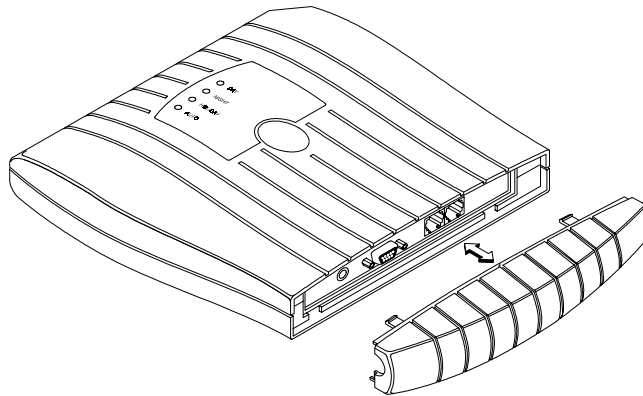

Figure 2-2 General View of the Unit after Removing the Cover

2.2.1 Side Panel

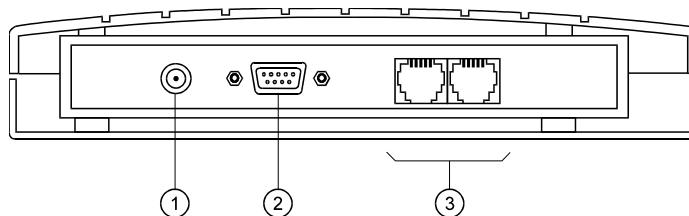

Figure 2-3 Side Panel

The numbered items in the following description correspond to the labels in Figure 2-3.

- | | | |
|----|------------------------|--|
| 1. | Power Supply Connector | Connects the unit to the external power supply |
| 2. | RS-232 Connector | Connects the unit to the PBX or a PC |
| 3. | 2 RJ-11 Sockets | Connects the unit to 2 or 4 PBX extensions |

2.2.2 Front Panel

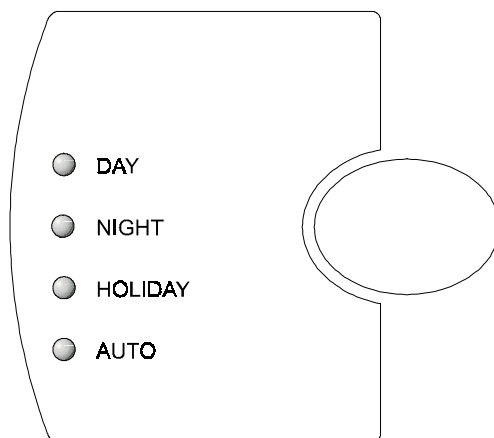

Figure 2-4 LEDs on the Front Panel

The following table describes the function of the four LEDs on the front panel.

STATUS	DAY	NIGHT	HOLIDAY	AUTO
Day Mode: Manual	On	Off	Off	Off
Night Mode: Manual	Off	On	Off	Off
Holiday Mode: Manual	Off	Off	On	Off
Break Mode: Manual	On	On	Off	Off
Day Mode: Auto	On	Off	Off	On
Night Mode: Auto	Off	On	Off	On
Break Mode: Auto	On	On	Off	On
System Error ¹	Off	Flashing	Off	Off
System Error ¹	Flashing	Flashing	Flashing	Flashing
System Error ¹	Flashing	Flashing	Flashing	Off
Automatic Self-Test	On	On	On	On

¹ Please contact your local dealer.

2.3 Installation

The unit is delivered completely assembled. It is designed for mounting on a wall close to the PBX.

2.3.1 Unpacking

Before unpacking, inspect the package, if you notice any damage, immediately report it to your local dealer.

➤ **To unpack the unit:**

1. Place the package on a flat surface and open it.
2. Remove the contents of the package and place them on a clean surface.
3. Remove all packing material.
4. Inspect the contents, if you notice any physical damage, immediately report it to your local dealer.

2.3.2 Installing the Unit

➤ **To install the Unit:**

1. Mount the Unit on a wall close to the PBX cabinet. Use the drill template to place the two screws.
2. Remove the side panel cover.
3. Connect the RJ-11 connector on one end of the cables to the RJ-11 sockets on the side panel of the Unit. Connect the other end of the cables to one or two analog telephone lines on the Main Distribution Frame (MDF) of the PBX (see Figure 2-5).

Note: Each RJ-11 socket on the side panel of the Unit can support up to two analog telephone lines.

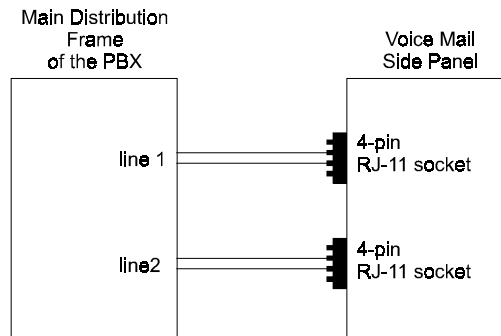

2 Line Connection

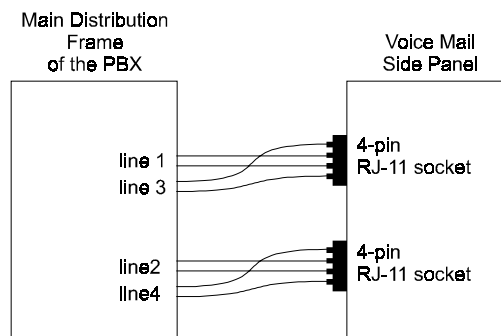

4 Line Connection

Figure 2-5 Analog Line Connections

4. On the side panel of the unit, plug the 9V DC adapter jack into the power supply connector.
5. Plug the 9V DC adapter into the main power supply outlet to turn the unit on. The LED's on the front panel turn on and off, one after another and then the LED indicating the status of the unit turns on.
6. If your PBX supports full authorized RS-232 integration with the unit, connect one end of the RS-232 cable to the unit's RS-232 connector and the other end to the RS-232 connector of the PBX.
7. Call each unit line from any extension and verify the answer. You should hear the default greeting (system message no. 000. See Appendix C).
8. Replace the side panel cover.
9. Program the unit according to your PBX type and required applications.

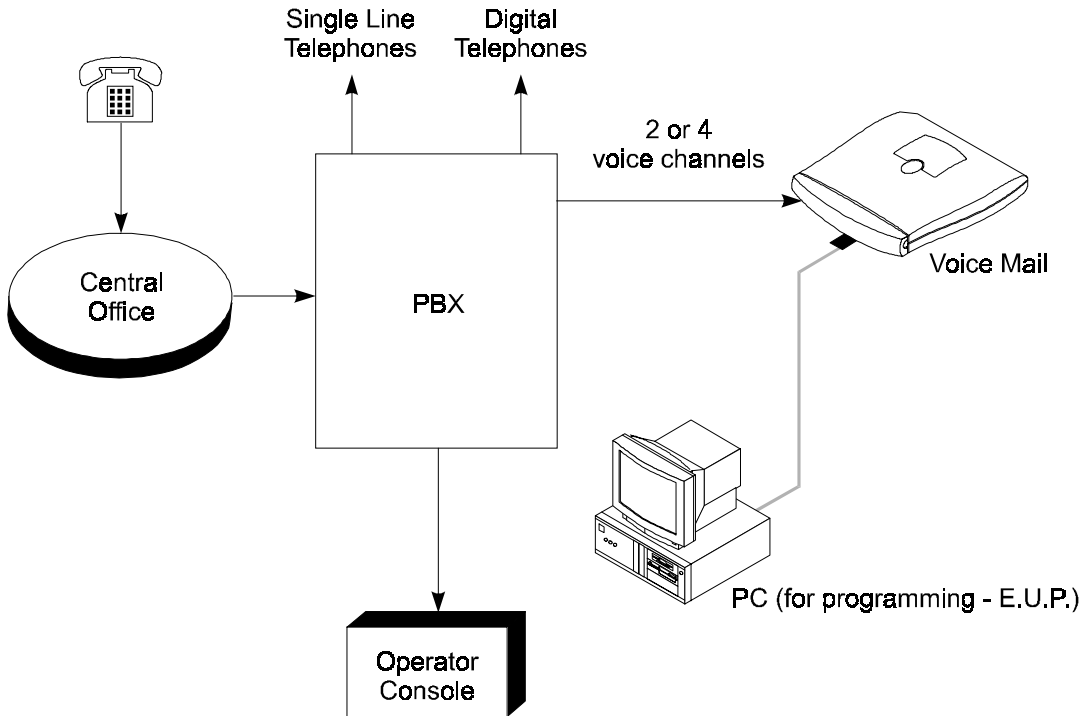

Figure 2-6 System Installation

2.3.3 Expanding the System to Four Lines

The two-line expansion kit contains:

- 2-line expansion card
- 4-wire cable
- Two plastic spacers

➤ **To install the expansion card:**

1. Disconnect all external cables and connectors.
2. Remove the 9V DC adapter power plug from the main power supply outlet to turn the Unit off.
3. Open the Unit's top cover by unscrewing the four screws.
4. Place the two plastic spacers into the corresponding holes.
5. Insert the expansion card into the corresponding J6 connector.
6. Connect one end of the 4-wire cable to J5 on the motherboard and the other end to J5 on the expansion card.
7. Replace the top panel cover and plug the 9V DC adapter into the main power supply outlet to turn the unit on.
8. Reconnect all the external cables and connectors to the unit.

Voice Mail System automatically detects four lines when it is turned on.

3. DTMF PROGRAMMING

The unit can be programmed by:

- Telephone using DTMF tones
- Computer using the Voice Mail Utility Program (see Section 4)

This section describes programming the unit using DTMF tones.

Note: You will hear a confirmation tone every time you enter a programming command.

3.1 Entering and Exiting the Programming Mode

The unit does not handle calls when in the programming mode.

➤ **To enter the programming mode:**

1. Connect a PBX analog line to the unit.
2. Call the PBX analog line from any touch-tone telephone.
3. Wait until the unit answers and plays the opening menu. Then dial *900.
4. Dial the System Administrator's password (the default password is 1234) to enter the programming mode.

➤ **To exit the programming mode:**

- Dial *900.
–or–
Do not dial for one minute.

*Note: If you exit the programming mode by dialing *900, the unit plays the opening menu and you can then test the changes made to the system.*

3.2 First Time Programming Checklist

1. Call from a touch-tone telephone to the unit. You will hear the default message (system message 000 - see Appendix C).



2. Dial *900 and the administrator password (default: 1234) to enter the programming mode.



3. Set the PBX parameters (see Sections 3.3 and Section 6) to ensure the proper operation of the unit with your PBX.



4. Set the unit's real-time clock (see Section 3.4).



5. Set the system schedule (see Section 3.5).



6. Create mailboxes (see Section 3.6.1).



7. Define a notification type for each mailbox (see Section 3.6.3).



8. Define notification parameters (i.e., message light on and message light off and interval between ring notification in Section 3.6.3.)



9. Record (see Section 3.7.1) and program (see Section 3.7.2) script menus for the Automated Attendant. Make sure you define the mailboxes before building Automated Attendant script menus.

3.3 Defining PBX Parameters

To integrate the unit with your PBX, apply the PBX parameters to the unit. To obtain your current PBX parameters, check your PBX User's Manual or the current PBX setup configuration.

To configure the unit to detect the in-band DTMF protocol sent by your PBX, refer to Section 6.

*Note: Do not forget to enter programming mode by dialing *900 and the administrators password before using the programming commands.*

Table 3-1 presents the commands you must enter to apply the PBX parameters to the unit.

Table 3-1 PBX Parameter Commands

OPERATION	COMMAND	DEFAULT
Extension size	*300 + X where X is a digit 1-4 You can only change this parameter if mailboxes and/or legal extensions have not yet been defined.	3
Cut off time for continuous call progress tone detection	*301 + X where: X = cut off time in seconds (0-9)	6 seconds
No. of rings before the line is answered	*310 + line number + number of rings Line number = 1-4 Number of rings = 1-9	1
Time to wait for No-Answer	*311 + XX where XX is 00-99 seconds. This code is applicable only when supervised transfer is selected.	20 seconds

Table 3-1 PBX Parameter Commands (continued)

OPERATION	COMMAND	DEFAULT
Legal PBX Extensions	<p>*320 + Y + First Ext. + Last Ext. + # where Y is a group number (0-9). Example: *320 0 330 350 # *320 1 355 375 #</p> <p>You can define up to 10 groups of legal extensions. If a caller dials an extension by direct dialing (code 170), The unit checks if the extension is legal. If the extension is not legal, The unit does not transfer the call.</p>	None
Resetting a group	*320 + Y + 000 + 000 + # (the two groups of zeros can be 2, 3, or 4 digits long, according to the extension size)	
Resetting all groups	*320 + #	
Operator ID Code	<p>*330 + X where X is a digit 0-9 When the caller dials this digit during any script message, the call is transferred to the operator.</p>	0
Programmable code for retrieving messages	<p>*331 + X X = 0-9; Retrieve digit</p>	9
Disconnection Code	<p>*333 + CODE¹ + #</p> <p>The unit terminates a call when it receives the disconnection code. The code can include up to four digits. Legal values for this code can be any combination of 0-9, *, #, and A-D.</p>	###
Clear Disconnection Code	* 333 + #	
External Access Code	<p>*340 + X + # where X is the external access code (0-9), Pause (*1). This code is applicable for external notification.</p>	9
Clear External Access Code	*340 + #	

Table 3-1 PBX Parameter Commands (continued)

OPERATION	COMMAND	DEFAULT
Pause before and after external access code	*341 + X where X is the length of the pause in seconds (0-9)	2 seconds
Transfer mode for all extensions	*350 + X + Y X = 1; All extensions except the operator X = 2; Operator extension only Y = 0; Non Supervised Y = 1; Supervised Mode Y = 2; Semi Supervised mode	Non supervised
Day operator, Night operator, Fax and Supervisor's extension numbers	*360 + X + YYYY + # where: X = 1; Day operator X = 2; Night operator X = 3; Fax extension X = 4; Supervisor extension <i>One mailbox can be defined as Supervisor. When storage memory reaches 80% of its capacity, a message is sent to this mailbox indicating the situation.</i> YYYY = Corresponding extension number.	0 0 - -
Delete the extension assignments	*360 + X + # where: X = 1; Day operator X = 2; Night operator X = 3; Fax extension X = 4; Supervisor extension	
Volume level	*369 + X where: X = volume level (0-9), 9 = Loudest	5
Flash-1	*370 + XXX where XXX is a 3-digit number (000-980) in steps of 20 ms. Example: *370 300 sets Flash-1 to 300 ms	600 ms
Flash-2	Flash-2 is fixed at 1200 ms. Flash-2 is used in some PBX's for Recall from No-Answer or Busy Codes.	1200 ms

Table 3-1 PBX Parameter Commands (continued)

OPERATION	COMMAND	DEFAULT
Busy, Disconnect and DTMF Off/On time	<p>*371 + X + YYYY where: X = 1; busy off (0100-3000 ms) X = 2; busy on (0100-3000 ms) X = 3; Disconnect off (0100-3000 ms) X = 4; Disconnect on (0100-3000 ms) X = *; DTMF off (0000-3000 ms) X = #; DTMF on (0000-3000 ms) YYYY = Cadence in milliseconds in steps of 20 milliseconds.</p>	<p>500 ms 500 ms 240 ms 240 ms 200 ms 60 ms</p>
Busy Signal Cadence Check	<p>*375 + XXXX + # where XXXX is a busy extension number. Check the busy signal by dialing the busy extension number and playing the busy cadence values.</p>	
Voice and DTMF Sensitivity	<p>*376 + X + Y X = 1; Voice sensitivity level X = 2; DTMF sensitivity level Y = Sensitivity level (0-9) The volume at which the unit detects voice when the called extension answers or the volume level at which the unit detects DTMF throughout it's operation. <i>Note: The higher the sensitivity level, the higher the sensitivity to voice or DTMF.</i> <i>In order to activate the new selection, a new call must be initiated.</i></p>	5
Automatic Gain Control (AGC)	<p>*377 + X X = 0 AGC disabled X = 1 AGC enabled When enabled, The unit will adjust the incoming messages volume to a set volume level. Note: For the new value to take affect, a new call must be initiated.</p>	Enabled
DTMF amplitude	<p>*379 + X where X = volume level (3-9), 9 = Loudest</p>	5

Table 3-1 PBX Parameter Commands (continued)

OPERATION	COMMAND	DEFAULT
Procedural codes sent to the PBX in order to perform a specific task	*380 + X + CODE¹ + # X = 1; LED1 notification code X = 2; LED2 notification code X = 3; LED notification off code X = 4; Transfer code X = 5; Recall from Busy X = 6; Recall from No Answer CODE¹ = Respective PBX code	None None None Flash 1 + Ext Flash 1 Flash 1
Delete a specific procedural code	*380 + X + # X = 1; LED1 notification code X = 2; LED2 notification code X = 3; LED notification off code X = 4; Transfer code X = 5; Recall from Busy X = 6; Recall from No Answer	
Dial a String from the Auto Attendant to the PBX	*381 + X + YY...YY + # X = String number (0-9) YY...YY = DTMF string <i>Note: Use CODE¹</i>	3.3
Answer number of samples	*386 + X where: X = number of samples (0-9)	5

CODE¹=

DTMF CHARACTER	NUMBER TO DIAL
Digits 0-9	0-9
*	**
Extension	*0
Pause	*1, indicates a 1 second pause
Hook Flash 1	*2
Hook Flash 2	*3
#	*4
A	*5
B	*6
C	*7
D	*8

3.4 Setting the Time and Date

Table 3-2 presents commands used to set the unit clock and calendar.

*Note: Do not forget to enter programming mode by dialing *900 and the administrator's password before using the programming commands.*

Table 3-2 Commands to Set the Unit Clock and Calendar

OPERATION	COMMAND
Setting the time and day of the week	<p>*420 + HH + MM where HH = hour (00-23) MM = minutes (00-59) Example: *420 15 25 stands for 3:25 p.m.</p>
Setting the date	<p>*430 + DD + MM + YY where DD = date of the month (01-31) MM = month (01-12) YY = year (00-99) Example: *430 15 03 97 March 15, 1997 <i>Note: 00 represents Year 2000.</i> <i>Note: The day of the week is automatically calculated by the system, based on the entered date.</i></p>
Listening to the system time	<p>*440 The system announces the date and time.</p>

3.5 Programming the Operational Mode

The unit can operate in Day, Night, Break, or Holiday mode. If the unit is in the Auto mode, it automatically changes modes according to programmed schedules.

*Note: Do not forget to enter programming mode by dialing *900 and the administrator's password before using the programming commands.*

Table 3-3 Programming the Operational Modes

OPERATION	COMMAND
Selecting an Operational Mode	<p>*400 + X where X stands for the operational mode. Day mode = 0 (default mode) Night mode = 1 Holiday mode = 2 Auto mode = 3 Break mode = 4</p>
Selecting time stamp format (Used by English and Chinese languages only)	<p>*410 + X where X = 0 means the time stamp is in 12-hour format (default) X = 1 means the time stamp is in 24-hour format</p>
Setting the Working Time (for Auto mode only)	<p>*450 + D + hh:mm + hh:mm where D is the day of the week (1-7)¹ First hh:mm = start of work time in 24 hour format Second hh:mm = end of work time in 24 hour format Repeat for all days of the week. Example: *450 1 08 30 1700 means that the unit will play the Day mode opening greeting on Monday from 8:30 until 17:00. It will play the Night mode opening greeting the rest of the time. ¹: Day 1 is Monday.</p>
Setting the Break Time (for Auto mode only)	<p>*460 + D + hh:mm + hh:mm where D is the day of the week (1-7)¹ First hh:mm = start of break time in 24 hour format Second hh:mm = end of break time in 24 hour format Repeat for all days of the week. Example 1: *460 1 13 15 14 30 This will play the Break mode opening greeting on Monday, from 13:15 until 14:30. ¹: Day 1 is Monday.</p>

Table 3-3 Programming the Operational Modes (continued)

OPERATION	COMMAND
Entering annual holiday dates (For Auto mode only)	*470 + DD + MM + hh:mm + hh:mm where: DD = Day of the month (01-31) MM = month (01-12) hh:mm = Start time; Hour and minutes in 24 hour format hh:mm = End time; Hour and minutes in 24 hour format Repeat for holidays Example 1: *470 02 12 08 15 23 45 The unit will play the Holiday mode opening greeting on December 2 nd , from 8:15 until 23:45.
Delete all holidays on a specific date	*470 + DD + MM # where: DD = Day of the month (01-31) MM = month (01-12)
Delete all holidays on a specific month	*470 + ** + MM + # MM = month (01-12)
Delete all holidays	*470 + #
External Notification Active Time	*490 + hh:mm + hh:mm where: hh:mm = Start time; Hour and minutes in 24 hour format hh:mm = End time; Hour and minutes in 24 hour format Example 1: *490 09 00 20 00 The will activate the External Notification between 9 a.m. to 8 p.m.

3.6 Programming the Unit

3.6.1 Creating Mailboxes

You can define up to 128 mailboxes. The mailbox number and its extension number are identical. Make sure that the number of digits in the mailbox number conforms to the number of digits in an extension (*300).

You can select one of the languages supported by the unit for each mailbox. After selecting a language, the unit:

- Plays all menus in the selected language.
- Plays all system messages (e.g., time stamp and error messages) in the selected language.
- If ring or remote notification is enabled, the mailbox owner is notified in the selected language.

A virtual mailbox can also be created for users who do not have extensions. When a caller dials a virtual mailbox number on the Automated Attendant menu, the call is immediately transferred to the Do Not Disturb menu and the caller is given the option to leave a message.

You may use the external notification features for the virtual mailboxes. Do not select internal notification because virtual mailboxes do not have extensions.

You can assign a mailbox for announcing messages without the ability to record incoming messages. This mailbox is called an Announcer mailbox. All mailboxes can be changed from a regular mailbox to an announcer mailbox and vice versa at any time.

*Note: Do not forget to enter programming mode by dialing *900 and the administrator's password before using the programming commands.*

Table 3-4 Commands to Create Mailboxes

OPERATION	COMMAND
Creating a range of mailboxes	*500 + First Mailbox + Last Mailbox + #
Creating one mailbox	*501 + Mailbox Number + #
Selecting an announcer mailbox	*502 + XXXX + Y + # where: XXXX = existing mailbox number Y = 0; Regular mailbox (default) Y = 1; Announcer mailbox
Deleting a mailbox	*510 + Mailbox Number + # Make sure to remove any transfer to the mailbox from the Automated Attendant scripts before deleting the mailbox.
Creating a range of virtual mailboxes	*520 + First Mailbox + Last Mailbox + #
Creating one virtual mailbox	*521 + Mailbox Number + #

Table 3-4 Commands to Create Mailboxes (continued)

OPERATION	COMMAND
Defining whether to play or skip the time and date stamp during message playback for a range of mailboxes	*530 + First Mailbox + Last Mailbox + B + # where B = 0; Play the date and time stamp (default) B = 1; Skip the date and time stamp
Defining whether to play or skip the time and date stamp during message playback for one mailbox	*531 + Mailbox Number + B + # where B = 0; Play the date and time stamp (default) B = 1; Skip the date and time stamp
Defining a language for a range of mailboxes	*532 + First Mailbox + Last Mailbox + Z + # where Z = 1, 2 or 3 (language number)
Defining a language for a mailbox	*533 + Mailbox Number + Z + # where Z = 1, 2 or 3 (language number)

3.6.2 Creating Mailbox Groups

You can create up to four mailbox groups for distributing messages. Each mailbox group can contain up to twenty mailboxes. The group numbers are by default 000, 001, 002 and 003. Group 099 consists of all mailboxes (real and virtual).

You can select a different number for the first digit of the mailbox groups using code *545. Make sure that you select a number that does not interfere with your PBX's numbering plan.

*Note: Do not forget to enter programming mode by dialing *900 and the administrator's password before using the programming commands.*

Table 3-5 Commands to Create Mailbox Groups

OPERATION	COMMAND
Adding a mailbox to a group	*540 + Group Number + Mailbox Number + # <i>Note: You must define the mailbox before adding it to a group.</i>
Changing the number of the first digit in the mailbox groups	*545 + X where X is the first digit of the mailbox groups. Default is 0.
Deleting a mailbox from a group	*550 + Group Number + Mailbox Number + #
Resetting a group	*560 + Group Number <i>Note: Resetting a group removes all the mailboxes within that group.</i>

Note: A separate greeting message can be recorded for each mailbox group.

3.6.3 Notification

The unit notifies the mailbox owner of new messages in different ways according to the system configuration. Notification may be local or remote.

Notification is *always done on the second line.*

Local Notification

You can select one of the following options:

- **None.** The notification feature is disabled.
- **Message Light On 1.** The Unit signals the PBX that a mailbox has received a message. The PBX then turns on the message light of the telephone extension. If the Message Light Off code is programmed, the code is transferred to the PBX after the mailbox owner retrieves all his new messages.

Some PBXs do not support the Message Light Off code. Instead they turn the message light off when the mailbox owner presses the message button on his proprietary telephone set and the Unit starts playing the messages (see Table 3-3).

- **Message Light On 2.** Same as Message Light On 1 but used only for PBXs that have two different codes for different telephones or for special tone notification (see Table 3-3).

The system administrator can set the notification method to one of the two states (code *760):

- Notification on 1st new message
 - Notification on every new message
- **Sign Rings.** The Unit rings the notified extension number. These Sign Rings may be sent at programmed intervals (code *720). The Unit stops sending Sign Rings after the mailbox owner retrieves all his new messages or the maximum number of retries has been made (code *750).
 - **Rings.** The Unit rings the notified extension for a programmed time period (code *730). When the mailbox owner answers, the Unit prompts him to enter his password. After entering the password, the mailbox owner may retrieve his messages. If the mailbox owner does not answer, the Unit tries again at programmed intervals (code *720). The Unit stops sending Ring notifications after the mailbox owner retrieves all his new messages or the maximum number of retries has been made (code *750).

Remote Notification

The mailbox owner may choose to be notified at a remote location (i.e., his mobile telephone, home telephone or pager) by entering a remote telephone number (of up to 20 digits) or pager number (of up to 40 digits). You can use any combination of *, #, A-D, 0-9, and Pause when setting the remote notification telephone number.

After remote notification is enabled, the Unit will dial the remote phone or pager number and notify the mailbox owner of any new messages. After entering the password, the mailbox owner can retrieve his messages. The duration of remote notification rings is programmed using code *730.

The Unit stops sending Ring notifications after the mailbox owner retrieves all his new messages or the maximum number of retries has been made (code *750). The mailbox owner must obtain permission from the System Administrator to enable remote notification. The System Administrator must use code *710 or *711 to grant permission.

The remote notification activation time can be programmed so the administrator can decide on the daylight hours for the external notification to be activated. The time span of this service is programmed using code *490.

When permission has been granted and the mailbox owner enables remote notification, the unit first dials the external access digit (programmed using code *340) and then dials the mailbox owner's remote telephone or pager number.

Note: Make sure that you enter the remote telephone or pager number before enabling remote notification.

Notification is *always done on the second line.*

3.6.3.1 Setting Notification for Mailboxes

*Note: Do not forget to enter programming mode by dialing *900 and the administrator's password before using the programming commands.*

Note: Virtual mailboxes do not have extensions and may not be configured for internal notification.

Table 3-6 Commands to Program Notification for Mailboxes

OPERATION	COMMAND
Setting local notification for a range of mailboxes	*700 + First Mailbox + Last Mailbox + X + # where X = 0 means notification is disabled X = 1 means Message Light On 1 is selected X = 2 means Message Light On 2 is selected X = 3 means Sign Rings is selected X = 4 means Rings is selected
Disable local notification for all mailboxes	*700 + #
Setting local notification for one mailbox	*701 + Mailbox + X + # where X is defined as above
Permitting remote notification for a range of mailboxes	*710 + First Mailbox + Last Mailbox + Y + # where Y = 0 means remote notification is not permitted Y = 1 means remote notification is permitted

Table 3-6 Commands to Program Notification for Mailboxes (continued)

OPERATION	COMMAND
Disable remote notification for all mailboxes	*710 + #
Permitting remote notification for one mailbox	*711 + Mailbox + Y + # Y = 0 means remote notification is not permitted Y = 1 means remote notification is permitted
Ring Notification Interval	*720 + XX where XX is a 2 digit number in minutes (1-99). Default = 30 minutes
Ring Notification Duration	*730 + X where X = 0 stands for short time for rings (default) X = 1 stands for long time for rings
Maximum number of days to store messages	*740 + XX where XX stands for number of days (00-99). 00 = Messages are not deleted by Voice Mail System.
Time to wait after off-hook for notification dialing	*741 + X X = Time in seconds (0-9)
Number of Ring Notification retries	*750 + XX where XX refers to the number of ring notification attempts. Default is 05.
Activate the LED notification	*760 + X where X = 0 for 1 st new message (Default) X = 1 for every new message.

3.7 Programming the Automated Attendant Script Menu

The unit supports up to 21 script messages (00-20) for building the Automated Attendant menu. The unit also supports another six script messages in three languages (21-26 for the first language, 31-36 for the second and 41-46 for the third) for Busy menu, No Answer menu, Do Not Disturb menu and Post Recording menu (see Section 3.7.5).

The opening scripts for each line are selected by command *112.

The following numbers are dedicated by default to specific script messages:

- Script message number 00 to the Day Mode Opening Menu
- Script message number 10 to the Night Mode Opening Menu
- Script message number 15 to the Break Time Opening Menu
- Script message number 20 to the Holiday Mode Opening Menu

The rest of the script messages (01-09, 11-14 and 16-19) may be used in all modes without limitations.

Each script message has three parts:

- Script message number
- Recorded announcement
- Programming that indicates the action to be taken when a caller dials one digit (0-9) or dials nothing during an announcement

3.7.1 Recording Script Messages

Table 3-7 describes how to record script messages.

Table 3-7 Commands for Recording Script Messages

OPERATION	COMMAND
Recording a script message	*100 + XX + Beep + Record + #
Playback a script message	*101 + XX
Deleting a script message	*102 + XX

Note: XX is script message 00-26, 31-36 and 41-46.

3.7.2 Programming Script Messages

You can program each script message separately. The programming command format for script messages is:

*** + Command Code + XX + B + YY + #**

where:

- **Command Code** defines the action that should be taken when B is pressed during playback of script message XX.
- **XX** refers to a script message number.
- **B** refers to the digit dialed by the caller during playback of script message XX or at the end of the message. B can be 0-9 or * (for end of message).
- **YY** refers to the destination, which can be an extension, mailbox or another script message.

IMPORTANT: Do not define the Operator ID digit on script messages.

Table 3-1 describes how to define the operator ID digit which is then automatically reserved on all script messages.

The command codes used to build the Automated Attendant Script Menu are presented on the following pages. You can program one of the following actions for each script message:

- Play another script message
- Return to the opening menu
- Play another script message and change the language
- Transfer the call to an extension
- Transfer the call to the operator
- Transfer the call to a mailbox
- Disconnect the line
- Leave a message in a mailbox
- Retrieve messages from a mailbox

- Direct dial to an extension
- Transfer a call directly to a mailbox
- Place a call on hold
- Blind Transfer to the busy extension
- Play the directory listing

Technicians and System Administrators should program the script messages according to the application.

3.7.2.1 End Of Message Timeout

Sets the EOM timeout period for each script individually.

Command: `*105 + XX + Y + #`

where:

XX = Script number

Y = Timeout in seconds

Example 1: *105 05 6 #

The Unit sets the EOM timeout to 6 seconds for script message 05.

3.7.2.2 Play Another Script Message

Builds submenus by transferring the caller from one script message to another.

Command: `*110 + XX + B + YY + #`

Example: *110 00 3 02 #

The unit plays script message 02 when “3” is dialed during playback of script message 00.

Note: Make sure to record script message 02.

3.7.2.3 Select Opening Script

Selects the opening script message.

Command: ***112 + XX + YY + Z + #**

XX = Default script number 00,10,15 or 20

YY = Replacement script number 00-20

Z = Line number 1-4

3.7.2.4 Transfer to the Opening Menu

Transfers the caller to the opening main menu. Used mainly by Busy and No-Answer script messages (21-24 for the first language, 31-34 for the second language and 41-44 for the third language), where the caller is given the option to return to the main menu.

Command: ***115 + XX + B #**

Example: *115 21 5 #

The unit plays the opening menu when “5” is dialed during playback of script message 21.

3.7.2.5 Transfer to a Script Message and Change the Language

Changes the system language and plays another script message. The unit supports up to three system languages simultaneously (factory loaded).

Command: ***117 + XX + B + YY + Z + #**

XX refers to the current script message

B refers to the digit dialed by the caller during playback of script message XX

YY refers to the destination script message

Z refers to the system language digit (1, 2 or 3)

Example: *117 00 7 01 3 #

The unit changes to the third language and plays script message 01 when “7” is dialed during playback of script message 00.

Note: Make sure that script message 01 has been recorded in the appropriate language.

3.7.2.6 Select the Default Language

The unit can support up to three languages. The default language is the language the unit automatically uses if no other language has been selected.

To change the default language, dial *900 and the administrator password to enter the programming mode, then dial:

***118 + Z + #**

Z = 1 is the first language (default)

Z = 2 is the second language

Z = 3 is the third language

Note: the available languages are listed on the bottom panel of the Unit.

3.7.2.7 Transfer the Call to an Extension

Transfers the caller to an extension or department (hunt group).

The designated extension number may contain up to 4 digits and does not have to be in the range of legal extensions.

Command: ***120 + XX + B + extension number + #**

Example 1: *120 05 3 123 #

The unit transfers the call to extension 123 when “3” is dialed during playback of script message 05.

Example 2: *120 00 * 1000 #

The unit transfers the call to hunt group 1000 at the end of script message 00.

3.7.2.8 Transfer the Call to the Operator at the End of the Script Message

Transfers the call to the operator at the end of the script message. The operator extension is defined in Table 3-1 (code *360).

The unit transfers the call in supervised, semi-supervised or non-supervised mode depending on code *350 (see Section 3.7.5).

Command: ***125 + XX + #**

Example: *125 00 #.

The unit transfers the call to the operator at the end of script message 00.

3.7.2.9 Transfer the Call to a Mailbox

Transfers the caller to a specific mailbox number. The mailbox must be defined (see Section 3.6.1).

Command: ***130 + XX + B + Mailbox number + #**

Example: *130 01 5 152 #

Transfers the call to mailbox 152 when “5” is dialed during playback of script message 01.

3.7.2.10 Disconnect the Line

Disconnects the call at the end of the script message or if the caller dialed the disconnect digit during playback.

This command may or may not include the system message 001

Command: ***140 + XX + B + Z + #**

Z = 0; means disconnect the line with no message.

Z = 1; means disconnect the line with the above system message

Example: *140 10 * 1 #

The unit plays the disconnection message and then disconnects the call at the end of script message 10.

3.7.2.11 Leave a Message in a Mailbox

Initiates the procedure for leaving a message in a mailbox.

Command: ***150 + XX + B + #**

Example: *150 00 8 #

The unit asks for a mailbox number when “8” is dialed during playback of script message 00. After dialing the requested mailbox number, the caller hears the mailbox’s greeting and can leave a message.

3.7.2.12 Retrieve Messages from a Mailbox

Initiates the procedure for retrieving messages from a mailbox.

Command: ***160 + XX + B + #**

Example: *160 00 9 #

The unit asks for a mailbox number and password when “9” is dialed during playback of script message 00. After dialing the requested mailbox number and password, the mailbox owner can retrieve his messages and access the user menu to record a personal greeting, change his password, etc.

3.7.2.13 Direct Call to an Extension

Enables the caller to dial an extension directly by programming the first digit of the extension. When a caller dials the first digit of an extension during playback of a script message, the unit stops the message and waits for the rest of the digits of the extension. The number of digits in an extension is defined by code *300 in Table 3-1. You can enter up to four different digits.

Command: ***170 + XX + first digit(s) + #**

Example 1: *170 00 2 #

The unit waits for the rest of the extension number when “2” is dialed during playback of script message 00. After the caller dials the rest of the extension number, the unit transfers the call to the extension.

Example 2: *170 00 2 4 #

Same as Example 1, except the extension number starts with 2 or 4 (for extension numbers 2xx and 4xx).

3.7.2.14 Transfer Call Directly to a Mailbox

Transfers the call directly to a mailbox number. This feature is similar to directly dialing an extension, except the call is transferred directly to a mailbox. You can enter up to four different digits.

Command: ***175 + XX + first digit(s) + #**

Example 1: *175 00 2 #

The unit waits for the rest of the mailbox number when “2” is dialed during playback of script message 00. After the caller dials the rest of the mailbox number, the unit transfers the call to the mailbox.

Example 2: *175 00 2 4 #

Same as Example 1, except the mailbox number starts with 2 or 4.

3.7.2.15 Place a Call on Hold

Gives the caller the option to remain on hold. Valid only for script messages 21-22 (for the first language), 31-32 (for the second language) and 41-42 (for the third language), which are reserved for the extension Busy menus.

Command: ***180 + XX + B + #**

Example: *180 21 3 #

The unit places the call on hold for 10 seconds before trying to transfer the call again when “3” is dialed during playback of script message 21.

3.7.2.16 Blind Transfer to a Busy Extension

Transfers a call in blind mode to a busy extension. Valid only for script messages 21-22 (for the first language), 31-32 (for the second language) and 41-42 (for the third language), which are reserved for the extension Busy menus.

Command: ***185 + XX + B + #**

Example: *185 21 5 #

The unit immediately tries to transfer the call again when “5” is dialed during playback of script message 21.

Note: Both Place a Call on Hold and Blind Transfer to a Busy Extension are used to transfer calls to a busy extension. Place a Call on Hold gives the option to retry every 10 seconds to transfer the call until the extension is available. In a Blind Transfer, calls are transferred to a Busy Extension immediately. This option is used when the unit is connected to a PBX that incorporates In-Band DTMF signaling.

3.7.3 Directory Listing Programming

The directory-listing feature (Dial By Name) allows calls to be transferred to proper extensions based on recorded names and codes of mailbox owners. The Directory Listing parameters are set through the commands explained in the following paragraphs.

3.7.3.1 Directory listing format

Changes the format of the directory listing. The unit supports two directory listing formats.

Command: ***011 + X**

X = 0; List according to last name (Default)

X = 1; List according to first name

3.7.3.2 Transfer to the directory listing

Transfers the call to the directory listing.

Command: ***111 + XX + B + #**

XX = Script number

Example: *111 00 5 #

Play the directory listing when “5” is dialed during playback of script message 00.

3.7.4 Reset Script Message Programming to Default

Resets a complete script message or only one entry. This command does not delete the recorded script message.

Resetting a Complete Script Message

Command: `*190 + XX + #`

Example: `*190 03 #`

Resets script message 03 to its default values.

Resetting One Entry in a Script Message

Command: `*190 + XX + B + #`

Example: `*190 02 5 #`

Resets entry 5 in script message 02 to its default value.

Default Values

- 0-9. If a caller dials a digit that has not been programmed (or set to default) during playback of a script message, the unit plays “This entry is not supported” and repeats the script message.
- If the caller dials the Operator ID code, the call is forwarded to the operator extension regardless of script message programming.
- At the end of a script message. If the caller does not dial a number during playback of a script message, the unit disconnects the call at the end of the message.

3.7.5 Supervised, Semi-Supervised and Non-Supervised Transfers

Transfer to an extension may be supervised, semi-supervised or non-supervised. In a supervised mode, the unit detects Busy and No-Answer signals from the PBX. In a semi-supervised mode, the unit only detects Busy signals. In a non-supervised mode, the unit transfers a call to the required extension without checking the status of the extension.

You can configure the unit to detect Answer, Busy and Do Not Disturb signals by recognizing the DTMF codes sent by the PBX or analyzing the Call Progress tones.

If DTMF signals are selected for the supervised mode, you must define DTMF codes for the Answer, Busy and Do Not Disturb conditions.

*Note: Do not forget to enter programming mode by dialing *900 and the administrator's password before using the programming commands.*

Table 3-8 Commands to Detect Answer, Busy and Do Not Disturb Conditions

OPERATION	COMMAND
Selecting DTMF code or Call Progress tone detection	*220 + X where X = 0; Supervised call transfer using Call Progress tones (default) X = 1; Supervised call transfer using DTMF codes
Defining the DTMF code for the Answer condition, Busy condition and Do Not Disturb condition	*221 + X + CODE¹ + # X = 1; Answer condition X = 2; Busy condition X = 3; Do Not Disturb condition CODE ¹ = DTMF code sent by the PBX for the Transfer Supervision operation 0-9, *, #, A-D See page 3-7 for the proper codes
Delete all DTMF condition codes	*221 + #
Delete the DTMF code for a specific condition	*221 + X + # X = 1; Answer condition X = 2; Busy condition X = 3; Do Not Disturb condition

If you select Call Progress tone supervision, the unit detects a busy tone based on the cadence parameters set using code *371. It detects an answer when voice is recognized. The unit does not check for Ring-Back tone cadences.

The unit distinguishes between two types of transfers:

- Transfer to operator
- Transfer to the rest of the extensions

Table 3-9 explains how to program supervised, semi-supervised and non-supervised transfers to the operator and to the rest of the extensions.

Table 3-9 Commands to Program the Transfer Modes

OPERATION	COMMAND
Transfer mode for all extensions	*350 + X + Y where X = 1; All extensions except the operator X = 2; Operator extension only Y = 0; Non-Supervised (Default) Y = 1; Supervised Y = 2; Semi-Supervised

3.7.5.1 Detecting a Busy Extension

If the unit detects a busy extension, it performs a Recall-from-Busy and by default plays system message 96 (if the extension has a mailbox) or 103 (if the extension does not have a mailbox). Refer to Section 3.7.5.3 for information on changing the default system messages.

3.7.5.2 Detecting a No Answer from an Extension

If the unit does not detect an answer from the extension, it performs a Recall-from-No-Answer and by default plays system message 97 (if the extension has a mailbox) or 104 (if it does not have a mailbox). Refer to Section 3.7.5.3 for information on changing the default system messages.

3.7.5.3 Changing the Busy and No Answer Menus

System messages 96, 97, 103, and 104 are default messages. The System Administrator can replace the system messages with script messages as follows:

- System message 96 (Busy and the extension has a mailbox) is replaced by script message 21 in the first language, script message 31 in the second language and 41 in the third language.
- System message 103 (Busy and the extension does not have a mailbox) is replaced by script message 22 in the first language, script message 32 in the second language and 42 in the third language.
- System message 97 (No-Answer and the extension has a mailbox) is replaced by script message 23 in the first language, script message 33 in the second language and 43 in the third language.

- System message 104 (No-Answer and the extension does not have a mailbox) is replaced by script message 24 in the first language, script message 34 in the second language and script message 44 in the third language.

For instructions on programming the above script messages, see Section 3.7.2. For instructions on recording the script messages, see Section 3.7.1.

3.7.5.4 Do Not Disturb

Using the user menu, a mailbox owner can activate the Do Not Disturb mode. When a caller dials a Do Not Disturb extension, the unit plays system message 121 and does not transfer the call to the extension. The System Administrator can replace this message with script message 25 in the first language, script message 35 in the second language and script message 45 in the third language.

3.8 Additional Features

3.8.1 Changing Passwords

The unit uses three types of passwords:

- System Administrator's password
- Operator's password
- Mailbox owner's password (see Section 5.4.4)

A password always contains four digits (0-9). The default for all three types of passwords is 1234.

3.8.1.1 Changing the System Administrator's Password

The System Administrator can change his password by dialing code *900 to enter the programming mode, dialing the current password and then dialing:

***600 + * + Old Password + New Password + #**

System administrator password must be 4 digits.

Warning: Do not use * and # keys.

Note: The System Administrator's password cannot be disabled.

3.8.1.2 Changing the Operator's Password

The System Administrator can change the operator's password by dialing code *900 to enter the programming mode, dialing the System Administrator's password and then dialing:

***601 + * + Old Password + New Password + #**

Operator's password must be 4 digits.

Warning: Do not use * and # keys.

To disable the operator's password, enter "0000".

3.8.1.3 Resetting the Mailbox Password

The System Administrator can reset a mailbox password to its default (1234) by dialing code *900 to enter the programming mode, dialing the System Administrator's password and then dialing:

***570 + XXXX + #**

where XXXX is the mailbox number.

The mailbox password can be changed by the mailbox owner. Please refer to section 5.4.4 for more information.

3.8.2 Activate Force Reorganize

The force reorganize option automatically reorganizes and optimizes the data stored in the unit.

The system administrator can activate the Force Reorganize option by calling the unit and, during the opening greeting, dialing:

***900 + Password + *610**

Important: This option cannot be deactivated, and should be activated by a certified technician only.

3.8.3 Changing to/from Day Light Saving Time

The operator can change to/from Day Light Saving time by calling the unit and, during the opening greeting, dialing:

***7 + XXXX + Y**

XXXX refers to the operator's password.

This password can be disabled. See Section 3.8.1.2.

Y = 0; Reduce the time by one hour

Y = 1; Increase the time by one hour

3.8.4 Changing the Operational Mode

The operator can change the operational mode by calling the unit and, during the opening greeting, dialing:

***8 + XXXX + Y**

XXXX refers to the operator's password.

This password can be disabled. See Section 3.8.1.2.

Y = 0; Day Mode

Y = 1; Night Mode

Y = 2; Holiday Mode

Y = 3; Auto Mode

Y = 4; Break Mode

3.8.5 Playing a System Message

To listen to any system message, dial *900 and the administrator password to enter the programming mode, then dial:

***690 + Z + XXX**

Z refers to the language number

Z = 1 is the first language

Z = 2 is the second language

Z = 3 is the third language

XXX is the message number

See Appendix C for a list of system messages.

3.8.6 Playing All System Messages

To listen to all system messages, dial *900 and the administrator password to enter the programming mode, then dial:

***691 + Z**

Z refers to the language number

Z = 1 is the first language

Z = 2 is the second language

Z = 3 is the third language

See Appendix C for a list of system messages.

3.8.7 System Message Setting

To determine if some of the system messages are played, dial *900 and the administrator password to enter the programming mode, then dial:

***699 + X + Y**

where X is system message affected:

X = 1 system message 004

X = 2 system message 102

X = 3 system message 095

Y = 0 play the message (default)

Y = 1 do not play the message

Y = 2 (only when X = 3) plays message to mailboxes without a greeting message

3.8.8 Listening to the Software Version Number

To hear the unit's software version number, dial *900 and the administrator password to enter the programming mode, then dial:

***680**

3.8.9 Resetting the System

The System Administrator can reset the unit to its factory default settings by dialing *900 and the administrator password to enter the programming mode, then dial:

***654 + * + XXXX + #**

where XXXX is the System Administrator's password.

Note: If you plan to reconfigure the unit for use with your current PBX and the unit had previously been configured for use with a different PBX type, use this command to clear all existing settings and return to the factory default settings.

3.8.10 Adjusting Recording Length

The System Administrator can select the length of the recorded messages in the unit. The selected length of message (in minutes) will affect all recorded messages. The types of recorded messages that are affected are: script recordings, mailbox owner's greetings, name recordings and recorded incoming calls.

To set message length dial *900 and the administrator password to enter the programming mode, then dial:

***790 + X**

where X = 1-9 minutes.

This parameter is set to two minutes by default.

4. PROGRAMMING BY COMPUTER

This section describes the purpose and main features of the Voice mail Utility Program (VUP) and details the installation process.

The VUP enables you to:

- Define PBX parameters
- Set the unit clock and calendar
- Create and maintain mailboxes
- Build Automated Attendant menus
- Review traffic statistics
- Print system parameters and statistics

Programming the unit via the PC is done offline until sent in one block to the unit.. We recommend that you save the new configuration in a file.

Using the VUP, you can also:

- Open a configuration file to make changes and then to upload them to the unit
- Open the default configuration file
- View unit statistics, e.g., line and memory utilization

4.1 Connecting The Unit To The Computer

➤ **To connect your computer to the unit:**

1. Remove the side panel cover of the unit.
2. Remove any cable attached to the unit's RS-232 connector.
3. Connect one end of the RS-232 cable to one of the unused serial ports of your PC and the other end to the Unit's RS-232 connector as shown in figure 4-1.

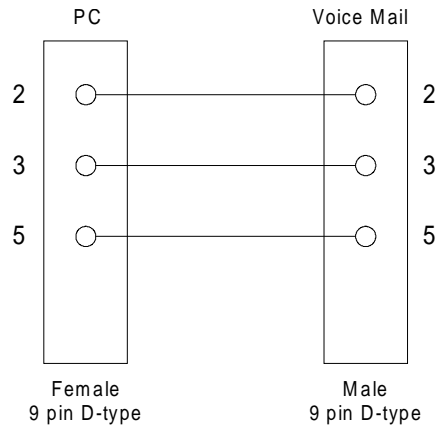

Figure 4-1 RS-232 Cable Connection

4.2 System Requirements

Before installing the VUP, check that your computer meets the following minimum requirements:

- PC 486 or higher
- 8 MB RAM free memory
- 5 MB free hard disk space
- Microsoft Windows 95, Windows 98 or Windows NT 3.51 or higher

4.3 Installing the VUP

➤ **To install the VUP:**

1. Exit all open applications.
2. Insert the VUP installation diskette into the floppy disk drive.
3. Use Windows Explorer to locate the setup file.
4. Double-click the setup file.
5. Follow the instructions on the screen.

4.4 Starting VUP

To start the VUP click on the VUP icon.

For further instructions go to the required parameter and press the F1 key.

Important: If the unit is programmed through VUP, the script message has to be recorded via a telephone set.

5. USER OPERATION INSTRUCTIONS

5.1 Introduction

The following paragraphs describe the user's operational menus.

5.2 User's Main Menu

Users can enter their mailbox menus for retrieving messages and set up their mailboxes in 3 ways, through the auto attendant using access digits for the retrieve message process (*160), by pressing an access digit during the mailbox greeting or by dialing the voice mail extension and if the PBX supports in-band DTMF protocol the users will automatically enter their mailbox menus. Then the unit announces the number of messages and plays the users menu:

DIGIT	NAME	DESCRIPTION
1	Retrieve Message	Listen to Messages
2	Mailbox Parameters	Enter Mailbox Parameters Menu
8	Send Message	Send a Message to a Specific Mailbox
9	Return to Auto Attendant	Exit Current Menu and Return to Auto Attendant

*Note: The User's main menu can also be entered by dialing the programmed "Key to retrieve messages" during the mailbox greeting playback. This parameter is programmed via command *331 or from the VUP. (Digit 9 is the default)*

5.3 Retrieve Message Menu

If the mailbox owner dials "1" while in user's main menu, the unit plays the new messages, followed by previously saved messages. At the end of each message, the unit plays the Retrieve Message menu:

DIGIT	NAME	DESCRIPTION
1	Next Message	Play next message
2	Replay	Replay current message
3	Save	Save current message
4	Forward	Forward current message to another mailbox
5	Reply	Reply to message sender (Internal messages only)
8	Delete	Delete current message
9	Return to Previous Menu	Return to previous menu (User's main menu)

5.4 Mailbox Parameters

If the mailbox owner dials "2" while in user's main menu, the unit plays the user's Parameters menu:

DIGIT	NAME	DESCRIPTION
1	Record Greeting	Record a greeting message for the mailbox
2	Record Name	Record your name
3	Directory Listing	Set directory listing parameters
4	Change Password	Change the mailbox access password
5	DND	DND Enable / Disable
6	External Notification	Set the external notification parameters (if allowed)
7	Pager Notification	Set the pager notification parameters (if allowed)
9	Return to Previous Menu	Return to previous menu (User's main menu)

5.4.1 Record Greeting

The mailbox owner can record a personal greeting by dialing “1” on the user’s parameters menu (see Section 5.4). The unit then plays the Record Greeting menu:

DIGIT	NAME	DESCRIPTION
1	Play Back	Play existing recording
2	Record	Record a new greeting message
8	Delete	Delete existing message
9	Return to Previous Menu	Return to previous menu (User’s parameters menu)

To record a greeting message for a mailbox group. Enter the mailbox group number as the mailbox number. The above menu will be played and a message may be recorded or altered.

5.4.2 Record Name

The mailbox owner can record his personal name by dialing “2” on the user’s parameters menu (see Section 5.4). The unit then plays the Record Name menu:

DIGIT	NAME	DESCRIPTION
1	Play Back	Play existing recording
2	Record	Record a new name
8	Delete	Delete existing name
9	Return to Previous Menu	Return to previous menu (User’s parameters menu)

5.4.3 Directory Listing

The mailbox owner can set the directory listing parameters by dialing “3” on the user’s parameters menu (see Section 5.4). The unit then plays the Directory Listing menu:

DIGIT	NAME	DESCRIPTION
1	Play Back	Play current directory listing code
2	Change	Change directory listing code
8	Delete	Delete Directory listing code
9	Return to Previous Menu	Return to previous menu (User’s parameters menu)

5.4.4 Change Password

A mailbox password consists of four digits. The default password is 1234. To disable the password, enter “0000”.

The mailbox owner can change his password by dialing “4” on the user’s parameters menu (see Section 5.4), dialing “2” (for the change password option) and then dialing the new password. Use digits 0-9 only when entering a password.

The System Administrator can reset the mailbox password to the default password by using code *570 or using the VUP.

DIGIT	NAME	DESCRIPTION
1	Play Back	Play the current password
2	Change	Change existing password
9	Return to Previous Menu	Return to previous menu (User’s parameters menu)

5.4.5 Do Not Disturb (DND)

The mailbox owner can dial “5” on the user’s parameters menu (see Section 5.4) to change to the Do Not Disturb mode. The unit announces the selected mode every time the mailbox owner changes the mode.

When a caller dials an extension in Do Not Disturb mode, the unit plays one of the following messages:

- By default, system message 121
- If recorded, script message 25 in the first language
- If recorded, script message 35 in the second language
- If recorded, script message 45 in the third language

5.4.6 External Notification

For activating the external notification of a mailbox, the System Administrator must enable this feature for the mailbox, thereafter, the mailbox owner can:

- Enable/disable remote notification
- Enter his remote telephone number
- Listen to the current remote telephone number

by dialing “6” on the user’s parameters menu (see Section 5.4).

DIGIT	NAME	DESCRIPTION
1	Change Mode	Toggles the external notification state (Enable/Disable)
2	Telephone Number	Enter the selected telephone number for external notification. Codes ¹ 0-9, Extension Number, *, #, A-D, P and Q can be used
8	Play Back	Play back the external telephone number
9	Return to Previous Menu	Return to previous menu (User’s parameters menu)

Codes¹:

P (1 second pause) = *1 # = *4 B = *6 D = *8 * = **
 Q (4 second pause) = *2 A = *5 C = *7 0-9 = 0-9

5.4.7 Pager Notification

For activating the external notification of a mailbox, the System Administrator must enable this feature for the mailbox, thereafter, the mailbox owner can:

- Enable/disable pager notification
- Enter his pager number
- Listen to the current pager number

by dialing “7” on the user’s parameters menu (see Section 5.4).

DIGIT	NAME	DESCRIPTION
1	Change Mode	Toggles the pager notification state (Enable/Disable)
2	Pager Number	Enter the selected pager number for pager notification. Codes ¹ 0-9, Extension Number, *, #, A-D, P and Q can be used
8	Play Back	Play back the pager number
9	Return to Previous Menu	Return to previous menu (User’s parameters menu)

Codes¹:

P (1 second pause) = *1 # = *4 B = *6 D = *8 * = **
 Q (4 second pause) = *2 A = *5 C = *7 Ext. No. = *0 0-9 = 0-9
 CPD Tone = *3

5.4.8 Return to Previous Menu

The mailbox owner can dial “9” on the user’s parameters menu (see Section 5.4) to return to the User’s main menu (see Section 5.2).

5.5 Send Message

The mailbox owner can leave a message in any mailbox or group of mailboxes by dialing “8” on the user’s main menu (see Section 5.4).

5.6 Return to Auto Attendant

The mailbox owner can dial “9” on the user’s main menu (see Section 5.2) to return to the auto attendant.

5.7 Quick Reference Guide

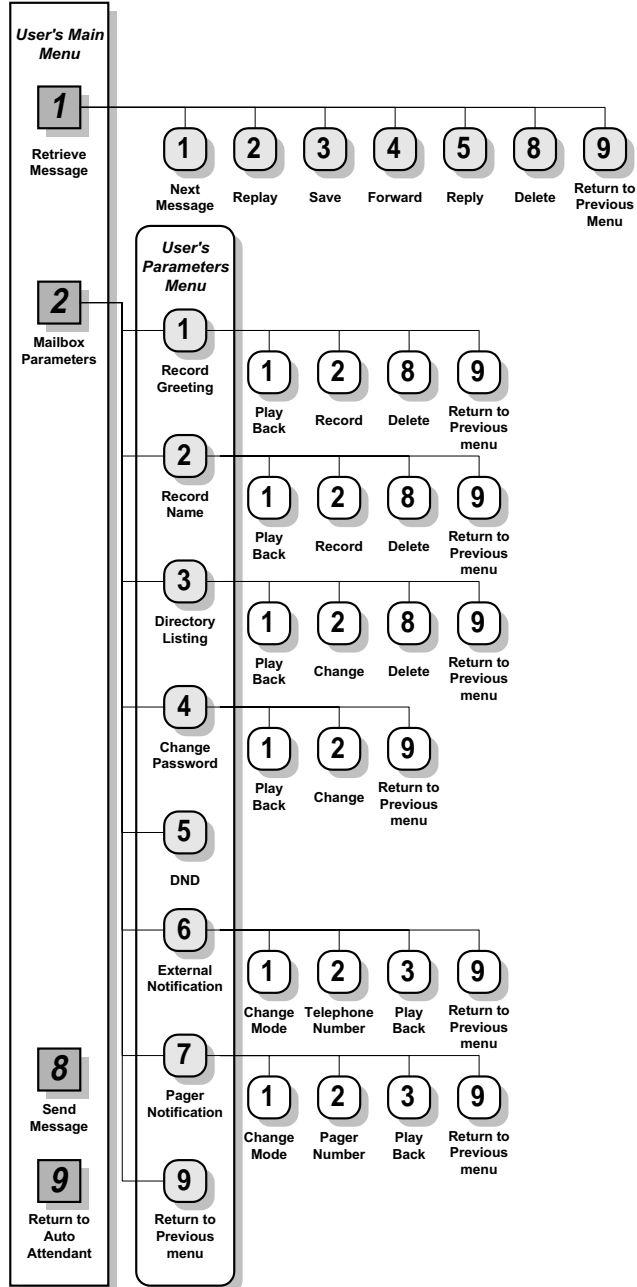

6. PROGRAMMING THE IN-BAND DTMF PROTOCOL

This section describes how to program the unit to detect In-Band DTMF codes sent by your PBX and to take appropriate action upon detection.

When the In-Band DTMF Protocol feature is programmed, the unit waits a defined period of time for an In-Band DTMF code after answering a call from the PBX. If the unit detects the code within the defined period of time, it performs a predefined operation. If the unit does not detect the code, it plays the Automated Attendant's Opening Greeting.

Note: After answering a call from your PBX, the unit plays the Automated Attendant's Opening Greeting under the following conditions:

- *The DTMF codes received from the PBX do not exactly match the programmed In-Band DTMF codes.*
- *The specified extension number (Target) called does not have a valid mailbox.*
- *The first DTMF character of the In-Band DTMF code was received after the specified period of time.*
- *The following DTMF characters were received outside the specified time frame*

You can program In-Band DTMF codes for up to ten events by:

- Touch tone telephone
- Computer running the Voice Mail Utility Program (VUP)

6.1 Programming the Unit by Telephone

The following sections present the command codes used to program the unit to detect and act on In-Band DTMF codes sent by your PBX.

6.1.1 Defining an In-Band DTMF Code for an Event

To define an In-Band DTMF code for an event, dial:

***200 + XX + YY...YY + #**

XX = Event number (00-19)

YY...YY = In-Band DTMF code sent by the PBX

Each DTMF code can contain up to twenty characters, including 0-9, A-D, *, #, source and target. You can also include the following two wild cards to bypass DTMF characters sent by your PBX and not relevant to the unit operation:

- Ignore + Length (*9 + two digit number). For example, wild card *906 programs the unit to ignore the next six DTMF characters received.
- Ignore + Separator (*0 + one digit character). For example, wild card *05 programs the unit to ignore all DTMF characters until it receives a 5. Wild card *0*4 programs the unit to ignore all DTMF characters until it receives a # (see Table 6-1).

Note: In the above examples 5 and # are also ignored.

Table 6-1 Entering an In-Band DTMF Code Using a Telephone

DTMF CHARACTER	NUMBER TO DIAL
Digits 0-9	0-9
*	**
#	*4
A	*5
B	*6
C	*7
D	*8
Ignore + Length	*9 + XX where XX is the number of DTMF characters to ignore
Ignore + Separator	*0 + X where X is the DTMF character (0-9, *, #, A-D) used as a separator
Source	*1, indicates the caller's number (not currently available)

Table 6-1 Entering an In-Band DTMF Code Using a Telephone (continued)

DTMF CHARACTER	NUMBER TO DIAL
Target	*2, indicates called extension number <i>Note: Dial *2 for each digit in the extension. For example, if your PBX is configured to support a 3-digit extension, dial *2 three times.</i>

6.1.2 Selecting an Operation Type

You can program each event to perform an operation. To select an operation type, enter:

***201 + XX + YY**

XX indicates the event number (00-19)

Y indicates the operation to be performed by the Unit according to the following options:

- 00 = Play the Automated Attendant's Opening Script
- 01 = Leave a message in a designated mailbox
- 02 = Retrieve messages from a designated mailbox
- 03 = Play a specific script¹
- 04 = Play the busy menu
- 05 = Play the No-Answer menu
- 06 = Play the Do Not Disturb menu
- 07 = Disconnect the call
- 08 = Record the conversation
- 09 = Play a specific script and change to 1st language¹
- 10 = Play a specific script and change to 2nd language¹
- 11 = Play a specific script and change to 3rd language¹
- 12 = Play the Directory Listing (DBN)
- 13 = Transfer to a mailbox¹
- 14 = Transfer to an extension¹
- 15 = Transfer to the operator

¹= A destination must be defined for these tasks. The destination of these operations is determined through code *202.

6.1.3 Selecting a destination

If you have programmed an event to play a script, transfer to an extension, or a mailbox dial the following command code to define the destination:

***202 + XX + YYYY + #**

XX = Event number (00-19)

YYYY = Script number, an extension number or a mailbox number

Note: Make sure the script message has been recorded if transferring to a script.

6.1.4 Defining the Time to Wait for the First DTMF Character

You can define the time period the unit must wait between answering a call and receipt of the first character of an In-Band DTMF code. If the unit does not detect a DTMF character within the defined period of time, it automatically plays the Automated Attendant's opening greeting.

To define the timeout until the first DTMF character, dial:

***210 + XXXX**

where XXXX = 0000-9980 ms in steps of 20 ms (The default is 3 seconds).

6.1.5 Defining the Time to Wait Between DTMF Characters

You can define the amount of time the unit must wait between receipts of each DTMF character comprising an In-Band DTMF code. If a DTMF character is not detected within the defined period of time and the In-Band DTMF code has not been completed, the unit automatically plays the Automated Attendant's opening greeting.

To define the amount of time to wait between DTMF characters, dial:

***211 + XXX**

where XXX = 000-980 ms in steps of 20 ms (The default is 500 ms.).

6.1.6 MATRA Support

The unit can support Q23 Protocol . To activated the support in Q23 :
Enter to programming mode and dial :

***204 + X**

where X=1 , unit support X=0 , unit not support

6.2 Sample Programming

6.2.1 Working with the SIEMENS Hicom 150E Office PBX

By default, the SIEMENS Hicom 150E Office PBX uses the following DTMF characters for integration with the unit:

***1 ** Source *1	Internal call to Voice Mail
***2 02222 *1	To activate the Automated Attendant (external call)
***3 ** Source Target *1	Call forward all (leave a message)
***4** Source Target *1	Call forward after no answer
***7** Source Target *1	Call forward after busy

Note: All source and target extension numbers in the SIEMENS Hicom 150E OfficePBX system have three digits.

6.2.1.1 Programming Using a DTMF Telephone

- **To program the unit to detect an In-Band DTMF code from the PBX and enable an internal caller to retrieve messages from a mailbox (***1 ** Source *1):**

1. Dial ***200 00 ** ** ** 1 ** ** *2*2*2 ** 1 #**

*200 is the programming code to define an In-Band DTMF code

00 is the event number assigned by you to the In-Band DTMF code

Each * in the above PBX DTMF code is replaced by **

*2*2*2 indicates the 3-digit extension number (Since The Extension is calling its mailbox, target is used instead of source)

indicates the end of the In-Band DTMF code.

2. Dial ***201 00 02**

*201 is the programming code to select an operation
00 is the event number ,02 is the unit's operation type that indicates
retrieving messages from a mailbox.

➤ **To program the Unit to detect an In-Band DTMF code from the PBX and enable an internal caller to leave a message in a mailbox (**3 ** Source Target *1):**

1. Dial ***200 02 ** ** ** 3 *905 *2*2*2 ** 1 #**

*200 is the programming code to define an In-Band DTMF code
02 is the event number assigned by you to the In-Band DTMF code
Each * in the above PBX DTMF code is replaced by **
*905 is a wild card programming the Unit to ignore 5 DTMF characters (**
Source)
*2*2 *2 indicates the 3-digit target extension number
Indicates the end of the In-Band DTMF code.

2. Dial ***201 02 01**

*201 is the programming code to select an operation
02 is the event number
01 is the Unit's operation type that indicates leaving a message in a
mailbox.

7. TROUBLESHOOTING

This section presents answers to commonly asked questions on operating the unit .

If problems persist, contact your dealer.

Question: **Local notification does not work.**

Answer:

- Make sure you have entered the correct notification codes.
- Make sure that local notification is enabled.
- Make sure that line 2 is properly connected between the unit and the PBX.
- Remove all the messages from the mailbox and then send a new message.
- Check unit's DTMF level and length.
- Add a pause between codes.
- For Rings or Sign Rings Notification, the first notification can take up to the amount of time defined by Ring Notification Interval.
- Make sure that for Rings and Sign Rings Notifications the maximum number of retries has not been reached.

Question: External Notification does not work.

- Answer:
- Make sure you have selected the correct External Access code.
 - Make sure you did not add the External Access code to the telephone number because the unit automatically dials the External Access code.
 - Make sure External Notification is allowed and enabled.
 - The first notification can take up to the amount of time that is defined by Ring Notification Interval.
 - Make sure start and stop times are properly defined and maximum number of retries has not been reached.

Question: The unit does not transfer calls. DTMF tones are heard or the call is disconnected.

- Answer:
- Flash 1 has been incorrectly configured.

Question: When I dial command code *300, the unit plays an error message.

- Answer:
- You are trying to change the number of digits in an extension after extensions and mailboxes have been configured. To change the number of digits in an extension, you must first remove all mailboxes and extensions.

Question: Command *510 does not allow a mailbox to be deleted.

- Answer:
- The mailbox is used in script menus. Please remove the mailbox from all the scripts and then use the delete command.

Question: In supervised mode, the Unit incorrectly returns calls.

Answer:

- The unit's time to wait for No-Answer parameter value is greater than the PBX's recall time parameter value. Decrease the value of the Unit's Time to Wait for No-Answer parameter or increase the value of the PBX's recall time parameters.

Question: In supervised mode, the unit does not recognize answered calls.

Answer:

- Increase the voice Sensitivity parameter value.
- Make sure that the correct Transfer Supervision Type has been selected.

Question: The unit transfers calls made to an extension to its mailbox and plays message stating that the extension is unavailable.

Answer:

- The extension is in Do Not Disturb mode.

Question: The Voice Mail Utility Program (VUP) issues a warning that the COM port is unavailable.

Answer:

- Make sure that the selected COM port is not being used by another device or Program.
- If the selected COM port was previously used by another device, remove the device, shut down and restart your computer to release the serial port.

Question: A message is sent to a mailbox group that contains five defined mailboxes but only two receive the message.

Answer:

- The messages were sent to all the mailboxes in the group but only accepted by those mailboxes that did not have the maximum number of messages recorded.

Question: The unit has been programmed to operate in Night mode. When a call is received, it disconnects the call and switches to Day mode.

Answer:

- Make sure that the night greeting script is recorded.

Question: What happens when a mailbox and mailbox group have the same extension number?

Answer:

- Messages are sent to the mailbox. In general, mailboxes have higher priority than mailbox groups.

Question: DTMFs dialed by the unit are not recognized by the PBX.

Answer:

- Change the amplitude and the ON and OFF levels of DTMFs dialed by unit (*379,*371).

Question: How can the password of the mailbox be reset to its default 1234.

Answer:

- Use command *570 or press The Reset button in the VUP.

Question: How can I find out how much memory is supported by my Voice Mail System.

Answer: • Use statistics option in VUP.

Question: Pager Notification does not work.

Answer: • Make sure you have selected the correct External Access Code.

 • Make sure you did not add the External Access Code to the pager number.

 • Make sure pager notification is allowed and enabled.

 • Make sure the pager number is entered correctly.

 • Make sure your pager company provides a 1400 Hz tone if '\$' is used.

 • If your provider does not support 1400 Hz tone SIT tone, use enough pauses to by-pass the sent tone.

 • The first notification can take up to the amount of time that is defined by Ring Notification Interval.

 • Make sure start and stop times are properly defined and maximum number of retries has not been reached.

Question: When I reach a mailbox, a menu is played immediately and I am not given a chance to leave a message.

Answer: • The mailbox is defined as an announcer mailbox.

Question: I have disabled the Automatic Gain Control but the messages are played louder than needed.

- Answer:
- Only messages recorded after the change are affected.
 - Initiate a new call after changing the AGC's status.

Question: How can I delete the messages of all users.

- Answer:
- Change the parameters "Maximum no. of days to store messages" to 1 (*740) and reorganize the system (*610).

Question: VUP's transfer operation is interrupted when large files are used with windows 98 or NT.

- Answer:
- Windows 98 and NT support a power save mode which interferes with serial ports operation. Disable this feature on PCs that run the VUP application.

APPENDIX A

PROGRAMMING COMMANDS

The following table presents a summary of DTMF programming commands.

Note: The DTMF column lists the sections in which the DTMF programming operations are discussed in this manual.

OPERATOR COMMANDS		
OPERATION	COMMAND	SECTION
Day Light Summer time	*7 + XXXX + Y XXXX = operator's password Y = 0; Reduce the time by one hour Y = 1; Increase the time by one hour	3.8.3
Change the operational mode (without entering the programming mode)	*8 + XXXX + Y XXXX = operator's password Y = 0; Day Y = 1; Night Y = 2; Holiday Y = 3; Auto Y = 4; Break	3.8.4

- The following programming codes are to be used after dialing *900 + administrator password.

SCRIPT PROGRAMMING COMMANDS		
OPERATION	COMMAND	SECTION
Directory listing format	*011 + X X = 0; Last name X = 1; First name	3.7.3.1
Record a script message	*100 + XX + Beep + Record + #	3.7.1
Play a script message	*101 + XX + Beep + Playback	3.7.1

SCRIPT PROGRAMMING COMMANDS (CONT'D)		
OPERATION	COMMAND	SECTION
Delete a script message	*102 + XX XX = Script No.	3.7.1
Select EOM timeout for each script	*105 + XX + Y + # XX = Script No. Y = Timeout in seconds	3.7.2.1
Transfer to a script message	*110 + XX + B + YY + #	3.7.2.2
Transfer to the directory listing	*111 + XX + B + # XX = Script number	3.7.3.2
Select opening menu	*112 + XX + YY + Z + # XX = Default script number 00,10,15 or 20 YY = Replacement script number 00-20 Z = Line number 1-4	3.7.2.3
Transfer to opening menu	*115 + XX + B + #	3.7.2.4
Transfer to a script message with a change of language	*117 + XX + B + YY + Z + # Z = 1, 2 or 3 (language number)	3.7.2.5
Set default language	*118 + Z Z = 1, 2 or 3 (language number)	3.7.2.6
Transfer to an extension	*120 + XX + B + Extension + #	3.7.2.7
Transfer to an operator	*125 + XX + #	3.7.2.8
Transfer to a mailbox	*130 + XX + B + Mailbox + #	3.7.2.9
Disconnect	*140 + XX + B + Z + # Z = 0, no message Z = 1 with message	3.7.2.10
Leave a message to a mailbox	*150 + XX + B + # XX = script No.	3.7.2.11
Retrieve messages from a mailbox	*160 + XX + B + #	3.7.2.12
Direct transfer to an extension	*170 + XX + first digit(s) + #	3.7.2.13
Direct transfer to a mailbox	*175 + XX + first digit(s) + #	3.7.2.14

SCRIPT PROGRAMMING COMMANDS (CONT'D)		
OPERATION	COMMAND	SECTION
Place a call on Hold	*180 + XX + B + #	3.7.2.15
Blind Transfer to Busy Extension	*185 + XX + B + #	3.7.2.16
Reset a specific message entry to its default value	*190 + XX + B + #	3.7.4
Reset all message entries to defaults	*190 + XX + #	3.7.4

IN-BAND DTMF PROGRAMING COMMANDS		
OPERATION	COMMAND	SECTION
Define an In-Band DTMF code for an event	*200 + XX + YY...YY + # XX = Event number YY...YY = In-Band DTMF code	6.1.1
Delete all In-Band DTMF codes	*200 + #	6.1.1
Delete In-Band DTMF codes for an event	*200 + X + # X = Event number	6.1.1
Select a task for an In-Band DTMF code	*201 + XX + YY XX = Event number YY = Task number: 00 = Auto Attendant opening script 01 = Leave a message 02 = Retrieve messages 03 = Play a specific script* 04 = Play a busy menu 05 = Play a No Answer menu 06 = Play a DND menu 07 = Disconnect the call 08 = Record the conversation 09 = Play a specific script and change to 1 st language* 10 = Play a specific script and change to 2 nd language* 11 = Play a specific script and change to 3 rd language*	6.1.2

IN-BAND DTMF PROGRAMING COMMANDS		
OPERATION	COMMAND	SECTION
Select a task for an In-Band DTMF code	12 = Play the Directory Listing (DBN) 13 = Transfer to a mailbox* 14 = Transfer to an extension* 15 = Transfer to the operator * = A destination must be defined for these tasks	6.1.2
Select a destination for an In-Band DTMF event	* 202 + XX + YYYY + # XX = Event No. YYYY = Destination	6.1.3
Delete the destination for a specific In-Band DTMF event	* 202 + XX + # XX = Event No.	6.1.3
Delete all destinations	* 202 + #	6.1.3
MATRA Support	* 204 + X	6.1.6
Define the time to wait for the first DTMF character in the In-Band DTMF code.	* 210 + XXXX XXXX = 0000-9980 in steps of 20 ms	6.1.4
Define the time to wait between receipt of each DTMF character in the In-Band DTMF code	* 211 + XXX XXX = 000-980 in steps of 20 ms	6.1.5
Define Transfer Supervision Type	* 220 + X X = 0; Use Call Progress Tones X = 1, Use DTMF codes	3.7.5
Define the DTMF code for the Answer, Busy and DND conditions	* 221 + X + Code¹ + # X = 1; Answer condition X = 2; Busy condition X = 3; Do Not Disturb condition Code ¹ = DTMF code sent by the PBX for the Transfer Supervision operation	3.7.5
Delete the DTMF code for a specific condition	* 221 + X + # X = 1; Answer condition X = 2; Busy condition X = 3; Do Not Disturb condition	3.7.5
Delete the DTMF code for all conditions	* 221 + #	3.7.5

PBX PARAMETERS		
OPERATION	COMMAND	SECTION
No. of digits in extension	*300 + X	3.3
Cut off time for continuous call progress tone detection	*301 + X X = cut off time in seconds (0-9) Default: 6 sec.	3.3
No. of rings before the line is answered	*310 + line number + number of rings	3.3
Time to wait for No Answer	*311 + XX	3.3
PBX legal extensions	*320 + Y + First Ext. + Last Ext. + # Y = group number (0-9)	3.3
Delete all PBX legal extensions	*320 + #	3.3
Operator ID code	*330 + X X = 0-9	3.3
Key To retrieve messages during mailbox greeting play back	*331 + X X = 0-9; Retrieve digit	5.2
Disconnect code	*333 + Code¹ + #	3.3
Delete disconnect code	*333 + #	3.3
External access code	*340 + X + # X = external access digit (0-9), Pause (*1)	3.3
Clear external access code	*340 + #	3.3
Pause before and after external access code	*341 + X X = pause length in seconds (0-9) Default: 2 sec.	3.3
Transfer mode for all extensions	*350 + X + Y X = 1; All extensions except the operator X = 2; Operator extension only Y = 0; Non Supervised Y = 1; Supervised Mode Y = 2; Semi Supervised mode	3.7.6

PBX PARAMETERS (CONT'D)		
OPERATION	COMMAND	SECTION
Day operator, Night operator, Fax and Supervisor's extensions	*360 + X + YYYY + # X = 1; Day operator X = 2; Night operator X = 3; Fax extension X = 4; Supervisor extension YYYY = Corresponding extension number.	3.3
Delete a specific extension assignment	*360 + X + # X = 1; Day operator X = 2; Night operator X = 3; Fax extension X = 4; Supervisor extension	3.3
Volume level	*369 + X X = volume level (0-9), 9 = Loudest Default: 5	3.3
Flash 1	*370 + XXX	3.3
Cadence of system input and output tones in milliseconds	*371 + X + YYYY X = 1; busy off X = 2; busy on X = 3; Disconnect off X = 4; Disconnect on X = *; DTMF off X = #; DTMF on YYYY = Cadence in milliseconds in steps of 20 milliseconds	3.3
Busy signal cadence check	*375 + XXXX + #	3.3
Voice and DTMF sensitivity	*376 + X + Y X = 1; Voice sensitivity level X = 2; DTMF sensitivity level Y = Level (0-9), 9 = Most sensitive Default: 5 Note: To activate the new selection, a new call must be initiated	3.3

PBX PARAMETERS (CONT'D)		
OPERATION	COMMAND	SECTION
Automatic Gain Control (AGC)	*377 + X X = 0 AGC disabled X = 1 AGC enabled (Default) Note: To activate the new selection, a new call must be initiated	3.3
DTMF amplitude	*379 + X X = volume level (3-9), 9 = Loudest Default: 5	3.3
Procedural codes sent to the PBX in order to perform a specific task	*380 + X + Code # X = 1; LED1 notification code X = 2; LED2 notification code X = 3; LED off code X = 4; Transfer code X = 5; Recall from Busy X = 6; Recall from No Answer Code = Respective PBX code ¹	3.3
Delete a specific procedural code	*380 + X + # X = 1; LED1 notification code X = 2; LED2 notification code X = 3; LED off code X = 4; Transfer code X = 5; Recall from Busy X = 6; Recall from No Answer	3.3
Dial a String from the Auto Attendant to the PBX	*381 + X + YY...YY + # X = String number (0-9) YY...YY = DTMF string	3.3
Answer number of samples	*386 + X X = number of samples (0-9) Default: 5	3.3

SETTING TIME & DATE		
OPERATION	COMMAND	SECTION
Change the operational mode	*400 + X X = 0; Day X = 3; Auto X = 1; Night X = 4; Break X = 2; Holiday	3.5
Select time stamp format	*410 + X	3.5
Set time and day	*420 + Hour + Minutes	3.4
Set date	*430 + Date + Month + Year	3.4
Listen to the system time	*440	3.4,
Set working hours	*450 + Day + Starting time + Ending time	3.5
Set break time	*460 + Day + Starting time + Ending time	3.5
Entering annual holidays dates	*470 + DD + MM + hh:mm + hh:mm DD = Day of the month MM = month hh:mm = Start time; Hour and minutes in 24 hour format hh:mm = End time; Hour and minutes in 24 hour format	3.5
Delete all holidays	*470 + #	3.5
Delete all holidays on a specific date	*470 + DD + MM # DD = Day of the month MM = month	3.5
Delete all holidays for a specific month	470 + ** + MM + # MM = month	3.5
External notification active time	*490 + hh:mm + hh:mm hh:mm = Start time; Hour and minutes in 24 hour format hh:mm = End time; Hour and minutes in 24 hour format	3.6.3

MAILBOX CONFIGURATION COMMANDS		
OPERATION	COMMAND	SECTION
Create a range of mailboxes	*500 + First mailbox + Last mailbox + #	3.6.1
Create a mailbox	*501 + Mailbox + #	3.6.1
Change to announcer mailbox	*502 + XXXX + Y + # XXXX = Existing mailbox number Y = 0; Regular mailbox Y = 1; Announcer mailbox	3.6.1
Delete a mailbox	*510 + Mailbox number + #	3.6.1
Create a range of virtual mailboxes	*520 + First mailbox + Last mailbox + #	3.6.1
Create a virtual mailbox	*521 + Mailbox number + #	3.6.1
Play or skip time and date stamp for a range of mailboxes	*530 + First mailbox + Last mailbox + B + # B = 0; Play the time and date B = 1; Skip the time and date	3.6.1
Play or skip time and date stamp for a mailbox	*531 + Mailbox number + B + # B = 0; Play the time and date B = 1; Skip the time and date	3.6.1
Define a language for a range of mailboxes	*532 + First Mailbox + Last Mailbox + Z + # where Z = 1, 2 or 3 (language number)	3.6.1
Define a language for a mailbox	*533 + Mailbox Number + Z + # where Z = 1, 2 or 3 (language number)	3.6.1
Add a mailbox to a group	*540 + Group number + Mailbox number + #	3.6.2
Change the first digit of the group numbers	*545 + First Digit of the Group Numbers	3.6.2
Delete a mailbox from a group	*550 + Group number + Mailbox number + #	3.6.2
Reset a mailbox group	*560 + Group number	3.6.2
Reset a user password	*570 + Mailbox number + #	3.8.1.3

SYSTEM FUNCTIONALITY COMMANDS		
OPERATION	COMMAND	SECTION
Change the system administrator's password	*600 + * + Old password + New password + # <i>Warning: Do not use the * or # keys.</i>	3.8.1.1
Change the operator's password	*601 + * + Old password + New password + # <i>Warning: Do not use the * or # keys.</i>	3.8.1.2
Forced reorganization	*610	3.8.2
Resetting the system to default	*654 + * + XXXX + # XXXX is the system administrator password	3.8.9
Listen to the software version number	*680	3.8.8
Play a system message	*690 + Z + XXX Z = 1 ,2 or 3 (language number) XXX = system message number	3.8.5
Play all system messages	*691 + Z Z= 1 ,2 or 3 (language number)	3.8.6
System message setting	*699 + X + Y X = 1; System message 004 X = 2; System message 102 X = 3; System message 095 Y = 0; Play Y = 1; Don't play Y = 2; (Only when X = 3) Play the message to mailboxes without a greeting message.	3.8.7

MAILBOX NOTIFICATION COMMANDS		
OPERATION	COMMAND	SECTION
Set local notification for a range of mailboxes	*700 + First mailbox + Last mailbox + X + # X = 0; disabled X = 1; LED 1 X = 2; LED 2 X = 3; Ring Signs X = 4; Rings	3.6.3.1
Disable local notification for all mailboxes	*700 + #	3.6.3.1
Set local notification for one mailbox	*701 + Mailbox + X + # X = 0; disabled X = 1; LED 1 X = 2; LED 2 X = 3; Ring Signs X = 4; Rings	3.6.3.1
Permit remote notification for a range of mailboxes	*710 + First mailbox + Last mailbox + X + # X = 0; not permitted X = 1; permitted	3.6.3.1
Disable remote notification for all mailboxes	*710 + #	3.6.3.1
Permit remote notification for one mailbox	*711 + Mailbox + X + # X = 0; not permitted X = 1; permitted	3.6.3.1
Ring Notification Interval	*720 + XX XX is in minutes (1-99)	3.6.3.1
Ring Notification Duration	*730 + X X = 0 means short ring X = 1 means long ring	3.6.3.1
Maximum no. of days to store a message in the system	*740 + XX XX is number of days 00-99.	3.6.3.1
Time to wait after off-hook for notification dialing	*741 + X X = Time in seconds (0-9)	3.6.3.1
Ring notification Retries	*750 + XX	3.6.3.1

MAILBOX NOTIFICATION COMMANDS (CONT'D)		
OPERATION	COMMAND	SECTION
Activate the LED notification	*760 + X X = 0 for 1 st new message X = 1 for every new message	3.6.3.1
Adjusting recording length	*790 + X X = 1-9 minutes	3.8.10

¹ Refers to PBX codes. Each code contains digits 0-9, *, #, Flash-1, Flash-2, Pause and Extension Number.

When entering a code, dial:

*0	for extension	*6	for B
*1	for pause	*7	for C
*2	for Flash-1	*8	for D
*3	for Flash-2	*9	for the number of new
*4	for #		messages in the mailbox
*5	for A	**	for *

APPENDIX B

PROGRAMMING FORMS

The following pages include forms to help you properly setup and maintain the Voice Mail System using DTMF programming commands.

OPERATION	COMMAND
Select opening menu	*112 ___ ___ # ___ ___ # ___ ___ # ___ ___ #
No. of digits in an extension	*300 _____
No. of rings before the line is answered	Line 1: *310 1 _____ Line 2: *310 2 _____ Line 3: *310 3 _____ Line 4: *310 4 _____
Time to wait for No Answer	*311 _____
Legal PBX extensions	Group 1: *320 0 ___ ___ # Group 2: *320 1 ___ ___ # Group 3: *320 2 ___ ___ # Group 4: *320 3 ___ ___ # Group 5: *320 4 ___ ___ #
Operator ID Code	*330 _____
Disconnect Code	*333 _____ #
External Access Code	*340 _____ #
Transfer mode	*350 _____ _____
Day Operator's Extension No. Night Operator's Extension No. Fax Extension No. Supervisor Extension No.	*360 _____ # _____ # _____ # _____ #
Flash 1	*370 _____

OPERATION	COMMAND
Cadence of System Input and Output Tones in Milliseconds	*371 ____ ____ ____ ____
Voice Sensitivity	*376 1 ____
Procedural Codes Sent to the PBX in Order to Perform Specific Tasks	*380 ____ #
Create a range of mailboxes Create a mailbox	*500 ____ # *501 ____ #
Create a range of virtual mailboxes Create a virtual mailbox	*520 ____ # *521 ____ #
Change the first digit of the group numbers	*545 ____
Add mailboxes to a group	Group 000: *540 000 ____ # Group 001: *540 001 ____ # Group 002: *540 002 ____ # Group 003: *540 003 ____ #
Maximum no. of days to store a message in the system	*740 ____

SETTING NOTIFICATION FOR MAILBOXES

Local notification for a range of mailboxes: *700 ____ ____ #

Local notification for one mailbox: *701 ____ #

Permitting remote notification for a range of mailboxes: *710 ____ ____ #

Permitting remote notification for one mailbox: *711 ____ #

External notification active time *490 ____ ____

NOTIFICATION PARAMETERS

Ring notification interval *720 ____

Ring notification duration *730 ____

Activate the LED notification *760 ____

SYSTEM TIME AND DATE

See Section 3.4 for information on setting the system time and date using codes *420 and *430.

SETTING THE HOLIDAY SCHEDULE

See Section 3.5 for information on setting the holidays using code *470

Day	Month	Start	End	Name of holiday
_____	_____	_____	_____	_____
_____	_____	_____	_____	_____
_____	_____	_____	_____	_____
_____	_____	_____	_____	_____
_____	_____	_____	_____	_____
_____	_____	_____	_____	_____
_____	_____	_____	_____	_____
_____	_____	_____	_____	_____
_____	_____	_____	_____	_____
_____	_____	_____	_____	_____
_____	_____	_____	_____	_____
_____	_____	_____	_____	_____
_____	_____	_____	_____	_____
_____	_____	_____	_____	_____
_____	_____	_____	_____	_____
_____	_____	_____	_____	_____
_____	_____	_____	_____	_____
_____	_____	_____	_____	_____

SETTING THE WORKING TIME

See Section 3.5 for information on setting the following schedule using codes *450 and *460.

Day	Working Hours		Break Time	
	Start	End	Start	End
1 (Monday)	_____	_____	_____	_____
2 (Tuesday)	_____	_____	_____	_____
3 (Wednesday)	_____	_____	_____	_____
4 (Thursday)	_____	_____	_____	_____
5 (Friday)	_____	_____	_____	_____
6 (Saturday)	_____	_____	_____	_____
7 (Sunday)	_____	_____	_____	_____

SETTING THE OPERATIONAL MODE

Operational Mode: *400 ____ Select: Day (0)/Night (1)/Holiday (2)/Auto (3)/Break(4)

This form contains the programming schedule for up to four script message. Please copy the form if you have more than four script messages.

Note: The following numbers are dedicated to specific script messages by default:

- *Script message number 00 to the Day Mode Opening Menu*
- *Script message number 10 to the Night Mode Opening Menu*
- *Script message number 15 to the Break Time Opening Menu*
- *Script message number 20 to the Holiday Mode Opening Menu*

The rest of the script messages (01-09, 11-14 and 16-19) may be used in all modes without limitations.

Script No. _____

0 _____

1 _____

2 _____

3 _____

4 _____

5 _____

6 _____

7 _____

8 _____

9 _____

EOM _____

Script No. _____

0 _____

1 _____

2 _____

3 _____

4 _____

5 _____

6 _____

7 _____

8 _____

9 _____

EOM _____

Script No. _____

0 _____

1 _____

2 _____

3 _____

4 _____

5 _____

6 _____

7 _____

8 _____

9 _____

EOM _____

Script No. _____

0 _____

1 _____

2 _____

3 _____

4 _____

5 _____

6 _____

7 _____

8 _____

9 _____

EOM _____

PROGRAMMING THE IN-BAND DTMF PROTOCOL

EVENT	IN-BAND DTMF CODE	TASK/ACTION	DESTINATION
0			
1			
2			
3			
4			
5			
6			
7			
8			
9			

COMMAND CODES USED TO PROGRAM THE IN-BAND DTMF PROTOCOL

OPERATION	COMMAND
Define an In-Band DTMF code for an event	*200 __ _____ #
Select a task for an In-Band DTMF code	*201 __ __
Select a destination for a specific in band DTMF event	*202 __ ____ #
Define the time to wait for the first DTMF character in the In-Band DTMF code	*210 _____
Define the time to wait between receipt of each DTMF character in the In-Band DTMF code	*211 _____
Define Transfer Supervision Type	*220 __
Define the DTMF code for the Answer, Busy and Do Not Disturb conditions	*221 __ ____ #

APPENDIX C

SYSTEM MESSAGES

This section lists the Voice Mail system messages and their numbers. You can hear each of these messages in the programming mode by dialing:

*690 + language digit (1, 2 or 3) + system message number

- or -

to hear all system messages dial:

*691 + language digit

NO.	SYSTEM MESSAGE
------------	-----------------------

000	This system has not been programmed. Please refer to the installation manual for instructions. Thank you!
001	Please hang up now.
002	Please enter your password.
003	Invalid entry. Please try again.
004	Please hold.
005	Message was received on...
006	At...
007	Zero
008	O'clock
009	No...

NUMBERS

010	One	024	Fifteen
011	Two	025	Sixteen
012	Three	026	Seventeen
013	Four	027	Eighteen
014	Five	028	Nineteen
015	Six	029	Twenty
016	Seven	030	Thirty
017	Eight	031	Forty
018	Nine	032	Fifty
019	Ten	033	Sixty
020	Eleven	034	Seventy
021	Twelve	035	Eighty
022	Thirteen	036	Ninety
023	Fourteen		

DATES

037	First	048	Twelfth
038	Second	049	Thirteenth
039	Third	050	Fourteenth
040	Fourth	051	Fifteenth
041	Fifth	052	Sixteenth
042	Sixth	053	Seventeenth
043	Seventh	054	Eighteenth
044	Eighth	055	Nineteenth
045	Ninth	056	Twentieth
046	Tenth	057	Thirtieth
047	Eleventh		

MONTHS

058	Of January	064	Of July
059	Of February	065	Of August
060	Of March	066	Of September
061	Of April	067	Of October
062	Of May	068	Of November
063	Of June	069	Of December

NO.	SYSTEM MESSAGE
------------	-----------------------

070	...and...
071	You have...
072	...new messages
073	...new message
074	...messages
075	To retrieve messages, press 1. To change mailbox settings, press 2. To send a message, press 8. To return to the main menu, press 9.
076	You have no messages.
077	Message saved. Please hold.
078	To skip this message, press 1. To replay, press 2. To save, press 3. To forward, press 4. To reply to message sender, press 5. To delete, press 8. To return to the previous menu, press 9.
079	Message saved.
080	Message deleted.
081	Please enter a new four digit password.
082	To delete skipped messages, press 8. To save all messages, press 9.
083	...yesterday...
084	...today...

NO. SYSTEM MESSAGE

- 085 Please enter your mailbox number.
- 086 Invalid mailbox. Please try again.
- 087 Incorrect password. Please try again.
- 088 Please record your greeting after the tone. Press the hash key when you have finished.
- 089 Please record your name after the tone. Press the hash key when you have finished.
- 090 Calls will be transferred to your extension.
- 091 Calls will not be transferred to your extension.
- 092 Please enter the mailbox number.
- 093 You have reached the mailbox of...
- 094 You have reached mailbox number...
- 095 Please leave a message after the tone. When you are finished press star for further options or simply hang up.
- 096 The required extension is busy. To try another extension, press 1 followed by the extension number. To hold, press 2. To leave a message, press 8. To transfer to the operator, press 0. To return to the Main Menu, press 9.
- 097 The required extension does not answer. To try another extension, press 1 followed by the extension number. To leave a message, press 8. To transfer to the operator, press 0. To return to the main menu, press 9.
- 098 The mailbox is currently unavailable.
- 099 The system is busy. Please wait.

NO. SYSTEM MESSAGE

100	a.m.
101	p.m.
102	You have a call.
103	The required extension is busy. To try another extension, press 1 followed by the extension number. To hold, press 2. To transfer to the operator, press 0. To return to the main menu, press 9.
104	The required extension does not answer. To try another extension, press 1 followed by the extension number. To transfer to the operator, press 0. To return to the main menu, press 9.
105	You have exceeded the maximum message length. Your message will be sent.
106	Sunday
107	Monday
108	Tuesday
109	Wednesday
110	Thursday
111	Friday
112	Saturday
113	O (As Eight-O-Two for 8:02)
114	Pause
115	Please record your message after the tone. Press the hash key when you have finished.

NO. SYSTEM MESSAGE

- 116 To change external notification, press 1. To enter the telephone number, press 2. To listen to the current telephone number, press 3. To return to the previous menu, press 9.
- 117 External notification is disabled.
- 118 External notification is enabled.
- 119 You have a new message. To retrieve messages press 1.
- 120 Please enter the telephone number. Press the hash key when you have finished.
- 121 The required extension is unavailable. To try another extension, press 1 followed by the extension number. To leave a message, press 8. To transfer to the operator, press 0. To return to the main menu, press 9.
- 122 Invalid extension number. Please try again.
- 123 Skipped messages have been deleted.
- 124 To listen to your recording, press 1. To rerecord, press 2. To delete, press 8. To return to the previous menu, press 9.
- 125 That recording does not exist.
- 126 The Busy On-Time is...
- 127 The Busy Off-Time is...
- 128 To listen to your password, press 1. To edit, press 2. To return to the previous menu, dial 9.
- 129 Message was received...
- 130 For Pager notification, press 1. To enter the pager number, press 2. To listen to the pager number, press 3. To return to the previous menu, press 9.

NO. SYSTEM MESSAGE

- 131 Pager notification is disabled.
- 132 Pager notification is enabled.
- 133 Please enter your pager number. Press the hash key when you have finished.
- 134 ...saved messages.
- 135 ...saved message.
- 136 That mailbox is currently unavailable.
- 137 Storage space is nearing capacity.
- 138 For...
- 139 ...press...
- 140 To return to the previous list, press 7.
- 141 For additional listings, press 8.
- 142 To enter another name, press 0. To return to the main menu, press 9.
- 143 No directory listing is available.
- 144 To record your greeting, press 1. To record your name, press 2. To access directory listing options, press 3. To change your password, press 4. To change the Do Not Disturb mode, press 5. To change external notification, press 6. To change pager notification, press 7. To return to the previous menu, press 9.
- 145 To listen to your directory listing, press 1. To enter your directory listing, press 2. To delete your directory listing, press 8. To return to the previous menu, press 9.
- 146 Operation Successful.

NO. SYSTEM MESSAGE

- 147 Using your keypad, please enter the first 3 letters of your last name. For Q press 7 for Z press 9.
- 148 Using your keypad, please enter the first 3 letters of the person's last name. For Q press 7 for Z press 9.
- 149 Using your keypad, please enter the first 3 letters of your first name. For Q press 7 for Z press 9.
- 150 Using your keypad, please enter the first 3 letters of the person's first name. For Q press 7 for Z press 9.
- 151 Your call is being transferred to...
- 152 To join the directory listing, please make sure your name is recorded.
- 153 Product version is...
- 154 To try another extension, press '1' followed by the extension number. To transfer to the operator, press '0'. To return to the Main Menu, press '9'.
- 155 This value has not been set.
- 156 To change mailbox settings, press 2. To send a message, press 8. To return to the main menu, press 9.
- 157 To skip this message, press 1. To replay, press 2. To save, press 3. To forward, press 4. To delete, press 8. To return to the previous menu, press 9.
- 158 To record your greeting, press 1. To record your name, press 2. To access directory-listing options, press 3. To change your password, press 4. To change the Do Not Disturb mode, press 5. To return to the previous menu, press 9

APPENDIX D

SPECIFICATIONS

DC Power Supply	9VDC/800mA
Line Voltage	24 to 72VDC
DC Leakage Current	> 10 μ A
On-hook Insulation Resistance between Line Terminal and the Ground	0 to 100VDC > 5M Ω 100 to 200VDC > 30K Ω 500 VAC/50Hz > 20K Ω 100 VAC/25Hz > 100K Ω
Ring Capacitor	0.47 μ F \pm 10%
On-hook Impedance	@ 50VDC, 40 VAC/25Hz > 3000 Ω
Ring Detect	27 to 100VAC/16 to 60Hz
DC Resistance (off-hook)	24 to 66VDC @ 20 to 100mA 100 to 350 Ω
Impedance (off-hook)	300 to 3400Hz 500 to 700 Ω
Imbalance Ratio	300 to 3400Hz > 46dB
Return Loss	300 to 3400Hz > 18dB
Current during Break	< 700 μ A
DTMF Transmission:	
Frequency Tolerance	+1.5%
Frequency Level (High Group)	-6 to -8dBm
Frequency Level (Low Group)	-8 to -10dBm
Inter-digit Pause in Tone Dialing	70 to 80ms
Fax CNG Tone Detection	1100Hz \pm 38Hz

